

## 1 Introduction

M-band filter banks are generalization of 2-band filter banks. For 2-band filter banks the signal is downsampled and upsampled by a factor of 2 but in the case of generalized M-band filter bank, the sequence is sampled by a factor of M.

In this lecture a specific case of M=3 called 3-band filter bank is considered and analyzed in depth which will help in understanding the generalization to any M.

## 2 3-Band Filter Bank (Ideal)

Similar to 2-band filter banks, we can define 3-band filter banks.

The above filter is true for any uniform 3-band filter bank *i.e.*, the length of all filters should

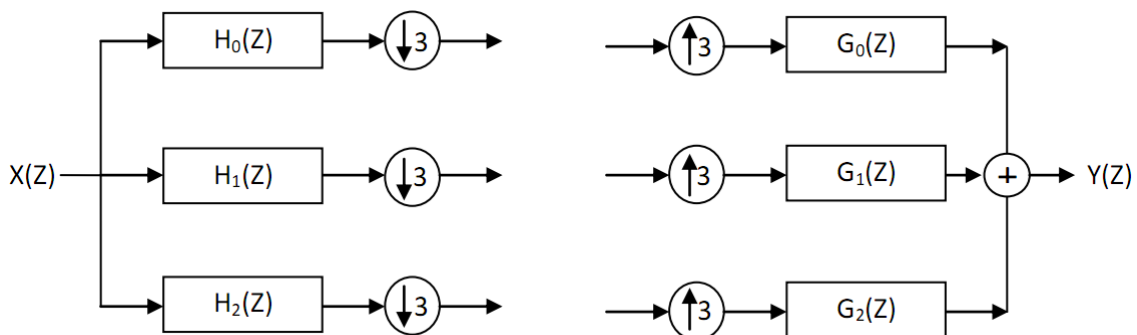

Figure 1: Analysis Side and Synthesis Side of a 3-band filter bank

be equal.

For ideal perfect reconstruction  $Y = X$ , but in general for perfect reconstruction the output  $Y$  can be a scaled or/and delayed function of  $X$ , also it can be a version of  $X$  with an easily invertible operation.

### 2.1 Analyzing an Ideal 3-Band Filter Bank

Conditions for perfect reconstruction:

$$H_0 = G_0$$

$$H_1 = G_1$$

$$H_2 = G_2$$

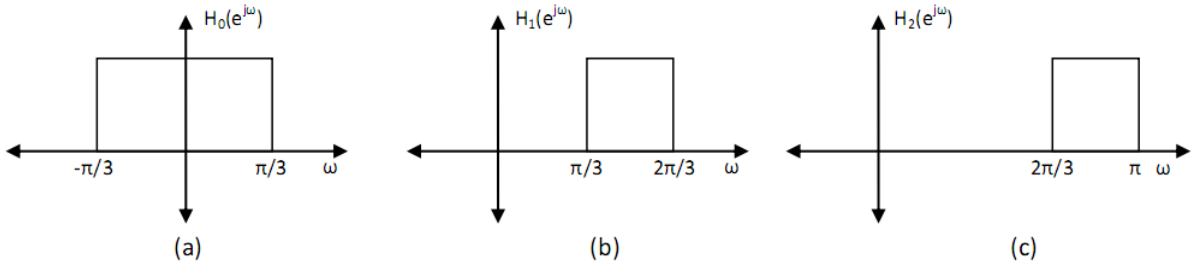

Figure 2: (a) $H_0$ : a low pass filter, (b) $H_1$ : a band pass filter, (c) $H_2$ : a high pass filter

### 2.1.1 Frequency responses of the ideal filters

Figure 2 shows the frequency responses of the ideal filter banks for a 3-band filter bank. As you can see the frequency axis is divided into three parts from 0 to  $\pi/3$ ,  $\pi/3$  to  $2\pi/3$  and  $2\pi/3$  to  $\pi$ , thereby covering the complete axis.

### 2.1.2 Frequency effect of Upsampling



Figure 3: Upsampling by 3

As can be seen there is a compression of frequency axis by a factor of 3.

Suppose we have a spectrum as shown in Figure.4(a), its upsampled version will be as shown in Figure.4(b) where frequency axis is compressed by a factor of 3.

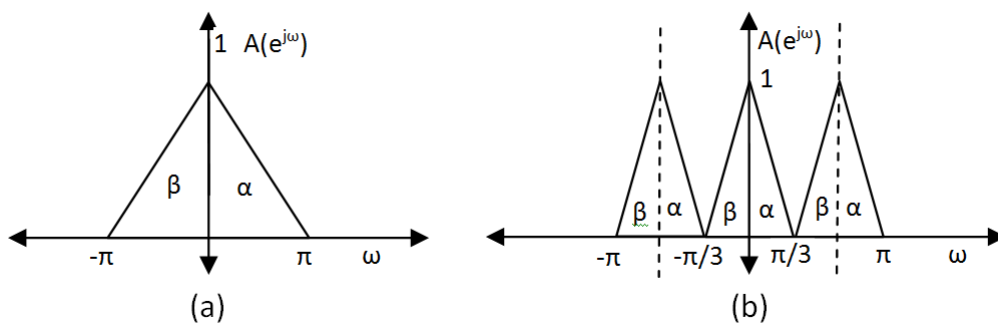

Figure 4: (a)Original spectrum,(b) Upsampled version by compressing frequency axis by a factor of 3

### 2.1.3 Frequency effect of Downsampling

Downsampling by a number creates aliases of the original spectrum *i.e.*, it will have original spectrum shifted and added.

Downsampling is effectively multiplying the sequence by  $..1001001001..$  and then compressing

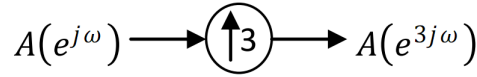

Figure 5: Downsampling by 3

it by throwing away the zeros obtained. Since ..1001001.. is a periodic sequence, it can be expressed in the terms of its IDFT by taking one period, finding its DFT and then IDFT giving us the sequence in form of modulates.

The above periodic sequence can be written as:  $\frac{1}{3} \sum_{k=0}^2 e^{\frac{j2\pi kn}{3}}$ . We multiply this expression with the sequence to be downsampled in frequency domain and then reduce the  $z^3$  to  $z$  to obtain the final downsampled version.

Effectively,

$$a[n] \longrightarrow \text{↓3} \longrightarrow a[n] \cdot \frac{1}{3} \sum_{k=0}^2 e^{\frac{j2\pi kn}{3}}$$

the above equation can be easily analyzed and solved in  $Z$ -domain, multiplying it and then replacing  $Z$  by  $Z^{\frac{1}{3}}$  to get the downsampled sequence.

**In  $Z$ -domain**

$$a[n] \xrightarrow{Z\text{-transform}} A(Z)$$

$$a[n] \frac{1}{3} \sum_{k=0}^2 e^{\frac{j2\pi kn}{3}} \xrightarrow{Z\text{-transform}} \sum_{k=0}^2 \frac{1}{3} A(Z e^{\frac{j2\pi k}{3}}) \quad (1)$$

now replace  $Z$  by  $Z^{\frac{1}{3}}$ , we get

$$A[Z] \longrightarrow \text{↓3} \longrightarrow \sum_{k=0}^2 \frac{1}{3} A[Z^{\frac{1}{3}}, e^{\frac{j2\pi}{3}k}]$$

**In sinusoidal frequency domain**

The last equation in the above section shows that the downsampled version of sequence is obtained by shifting its DTFT on the frequency axis by  $\frac{2\pi}{3}$  for  $k = 0, 1, 2$  and adding. After adding the shifted DTFTs, scale it vertically by  $\frac{1}{3}$  and horizontally stretch by a factor of 3 to get the final downsampled by 3 version.

## 2.2 Interpretation of 3-band filter bank

### 2.2.1 Low frequency interpretation

Now, let us analyze the effect of the 3-band filter bank in a low frequency region on a prototype spectrum.

Figure 6 shows the prototype spectrum which is going to be analyzed. Spreaded over the whole frequency range with variable amplitude assuming 0 phase. Subject this spectrum to

$$A[e^{j\omega}] \rightarrow \left( \downarrow 3 \right) \rightarrow \frac{1}{3} \sum_{k=0}^2 A[e^{j(\omega+2\pi)k/3}]$$

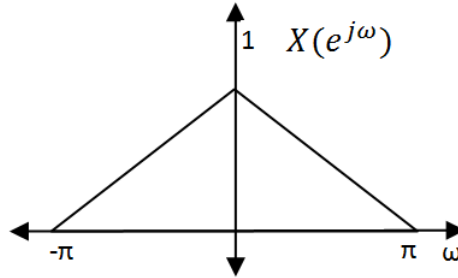

Figure 6: Prototype spectrum

the low pass branch in the ideal 3 band filter bank which has a cut off frequency of  $\frac{\pi}{3}$  and a downsampler of 3. Firstly, spectrum obtained after passing it through the low pass filter is shown in figure 7.

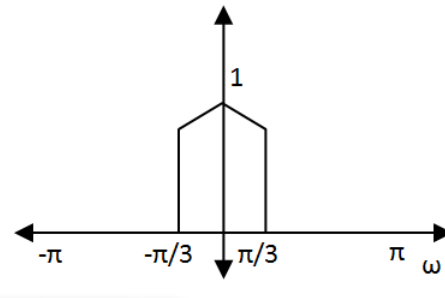

Figure 7: Low pass spectrum

Secondly, spectrum obtained after translating to multiples of  $\frac{2\pi}{3}$  and adding is shown in figure-8.

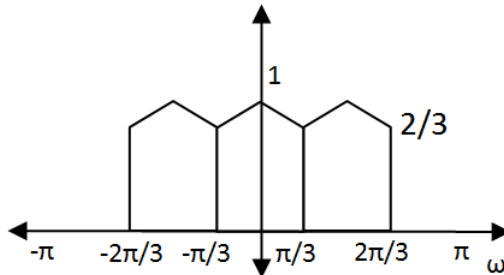

Figure 8: Translated by multiples of  $\frac{2\pi}{3}$  and added

Lastly, the spectrum obtained by scaling vertically by a factor of  $\frac{1}{3}$  and horizontally by a factor of 3 is shown in figure 9. Now, for synthesis we upsample it by 3 and pass it through the synthesis low pass filter. It

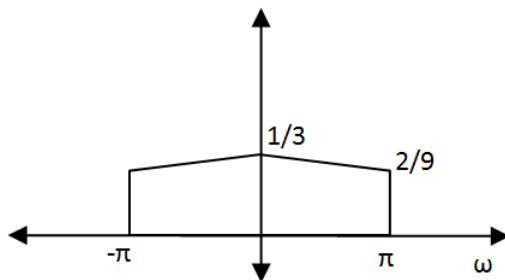

Figure 9: Spectrum obtained after subjecting to analysis filter bank

retains the scaled version of the original filter and destroys the aliases. The spectrum obtained is as shown in figure 10.

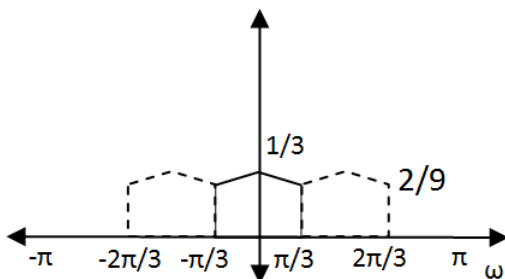

Figure 10: Spectrum obtained after subjecting the sequence to low frequency branch

Aliases gets created in between the analysis and synthesis filters because we wish to retain the total amount of data. The total number of samples per unit time at the input of the analysis filter is reduced to one third at the outputs of the each of the downsamplers. Thus, total amount of information remains the same at any point of time.

### 2.2.2 Middle branch interpretation

On the analysis side of the middle branch we have a bandpass filter between  $\frac{\pi}{3}$  and  $\frac{2\pi}{3}$  followed by a downsampler of 3.

Lets take the same prototype spectrum, when subjected by a bandpass filter we obtain a spectrum as shown in figure 11.

After passing it through the bandpass filter, a downsampler by 3 acts on the spectrum. The spectrum is translated by shifts of multiples of  $\frac{2\pi}{3}$  and added as shown in figure 12. To obtain the final downsampled version, the spectrum is scaled vertically by a factor of  $\frac{1}{3}$  and horizontally by a factor of 3. Spectrum obtained is as shown in figure 13.

Now, for synthesis we upsample it by 3 and pass it through the synthesis low pass filter. It retains the scaled version of the original filter and destroys the aliases. The spectrum obtained is as shown in figure 14.

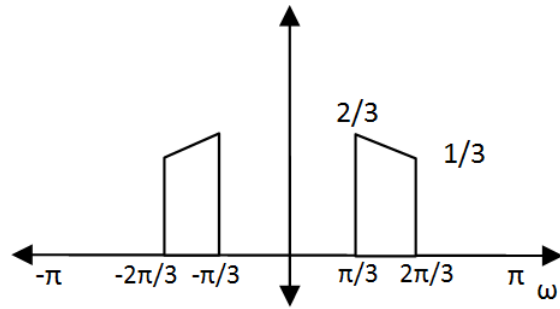

Figure 11: Band pass version of the signal

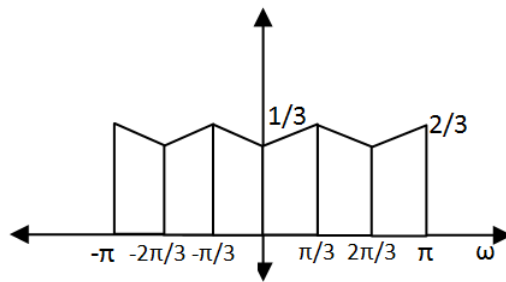

Figure 12: Translated by multiples of  $\frac{2\pi}{3}$  and added

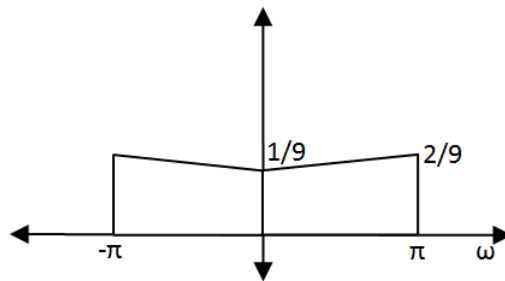

Figure 13: Middle branch spectrum after subjecting to analysis side

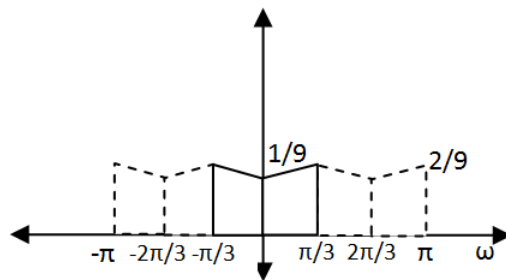

Figure 14: Reconstructed Middle branch spectrum