

Lecture 31: The Wave Packet Transform

Prof. V.M. Gadre, EE, IIT Bombay

1 Introduction

In the previous few lectures, we have been looking at the variants of the wavelet transform or of time-frequency analysis. In fact, we have looked so far at the short time fourier transform (STFT) and continuous wavelet transform (CWT). We have also seen the discretization of CWT in scale and then in translation. We have studied the specific case of dyadic discretization ($a_0 = 2$) of scale and a corresponding uniform discretization of the translation parameter. Following that, we have brought in the possibility of biorthogonal multiresolution analysis (biorthogonal MRA) and we took inspiration for biorthogonal MRA by considering the need to construct ‘**splines**’ (piecewise polynomial functions). So essentially, we looked at the possibility of piecewise polynomial interpolation and when we went from piecewise constant which gave us the Haar Multiresolution Analysis to piecewise linear, we noted that, we have two options either we use the same analysis and synthesis filters (i.e. same scaling and wavelet functions at analysis and synthesis side) or we make synthesis side different from the analysis side.

Over the past two lectures, we realized that if we insisted on constructing in orthogonal multiresolution analysis with piecewise linear scaling functions and wavelets, we had a very difficult task before us, of course it is achievable that we can get orthogonal multiresolution analysis from piecewise linear functions, but it is extremely cumbersome to construct those scaling functions and wavelets. Moreover, they are of infinity length and we loose the compact support. If we wish to stick to compactly supported scaling functions and wavelets or rather we wish to stick correspondingly to the finite impulse response filters on the analysis and synthesis side, then we need to bring in a variant of the multiresolution analysis called ‘**Biorthogonal MRA**’. We have so far introduced the biorthogonal MRA only from the perspective of the filter bank and for the moment we intend to remain there. Later we shall look at its implication in continuous time or in iteration. In this lecture, we wish to look at one more variant of multiresolution analysis, but this time it is variant on the iteration of the filter bank, this is called a ‘Wave packet transform’ and therefore this lecture is appropriately titled, ‘**The Wave Packet Transform**’.

2 The wave packet transform

The idea behind the Wave Packet transform is very simple, so far when constructing the dyadic discrete wavelet transform (DWT), we always insist it to decompose the so called approximation subspace. Let us put this notion graphically called ladder of subspaces about which we are speaking very often as shown in figure 1. Every time we have pilled off an incremental subspace.

In the wave packet transform our objective is to get around this limitation, so what we intend to do is to decompose the incremental subspace (i.e. detail subspace) as we do the approximation subspace. For example we decompose V_1 into V_0 and W_0 , we also intend to decompose

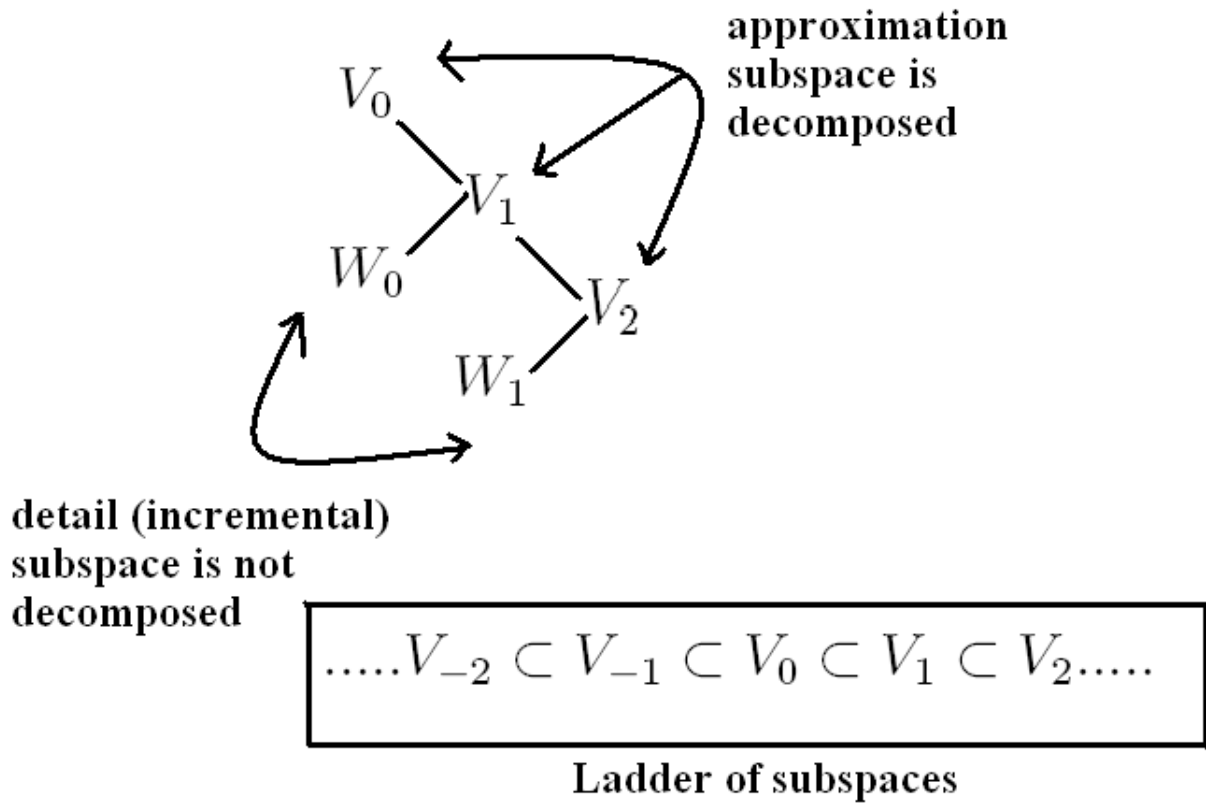

Figure 1: Notion of decomposition of subspaces in DWT

W_0 in the next step.

In one sentence the idea behind the Wave Packet transform is:

Idea:

Decompose the incremental or detail subspace also.

Now towards this objective, the simplest approach would be to look at the filter bank structure, so in fact this time instead of starting from the basis or the continuous time functions, let us begin from the filter bank.

Let us assume that you have a sequence representing the function in an approximation subspace. For simplicity, let us take the subspace V_2 i.e. it is a sequence of coefficients in the expansion of given function in $L_2(R)$ in terms of basis of V_2 . Now remember that the filter bank operates on these coefficients and creates coefficients of expansion in V_1 and W_1 using the lowpass and highpass analysis filters. So in another words, the filter bank is iterated on the lowpass branch. Suppose we also choose to iterate the filter bank on the highpass branch.

Essentially what is going to give us is so called Wave packet transform.

Let us first investigate from the ideal i.e. ideal frequency behavior of the filter bank. In the DWT as shown in figure 2, consider a sequence of coefficients is subjected to analysis low-pass and highpass filters (ideal with cutoff $\pi/2$) and followed by a downsampling operation. At point 'A', we get coefficients in the lower approximation subspace and at point 'B' in the detail subspace.

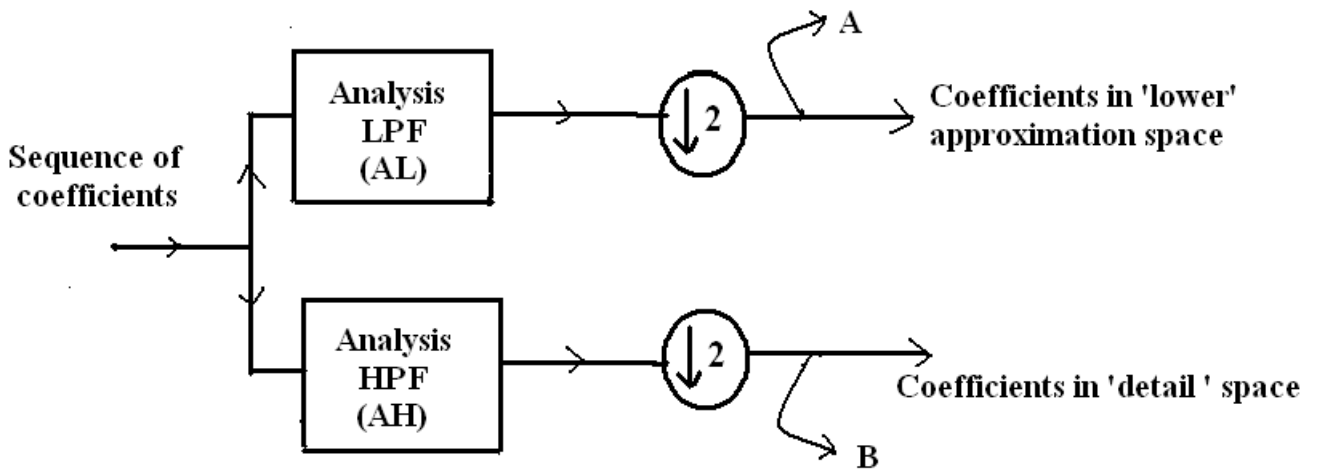

Figure 2: One level of DWT

Now, the next time we will take the entire structure of figure 2 and will put at point 'A' to get two level DWT as shown in figure 3. This gives us the two-level DWT, note that here the high pass branch is not iterated.

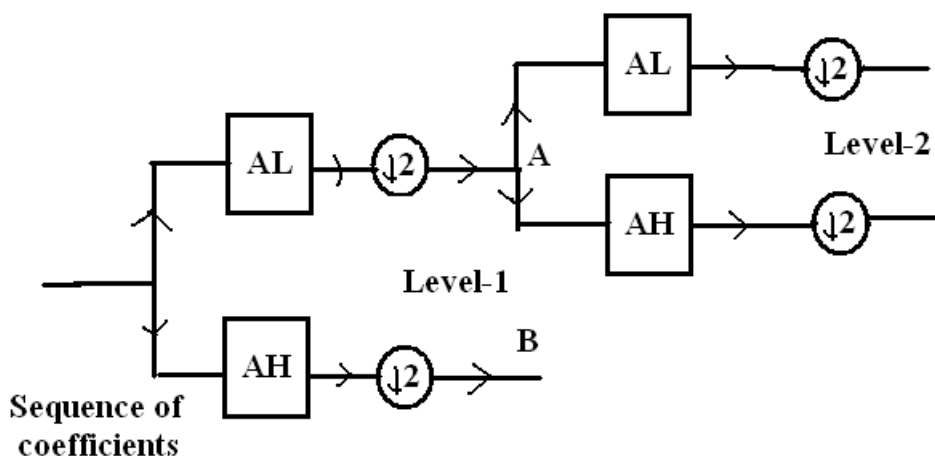

Figure 3: Two level of DWT

It is interesting to see that what we will get Wavepacket transform if highpass branch is also

iterated as shown in figure 4. Now, whatever we will get will be additional which we want to investigate it. Consider that all the filters are ideal. Let 'IAL' and 'IAH' are ideal analysis lowpass and ideal analysis highpass filters with cutoff $\pi/2$ respectively. Let us analyze the

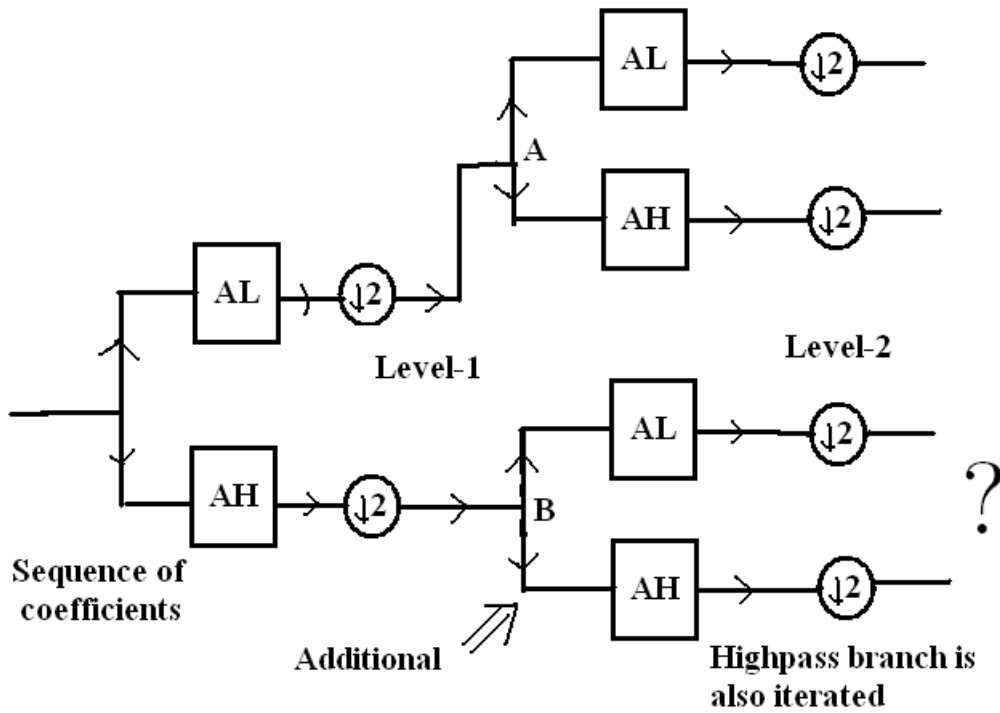

Figure 4: Wave packet transform

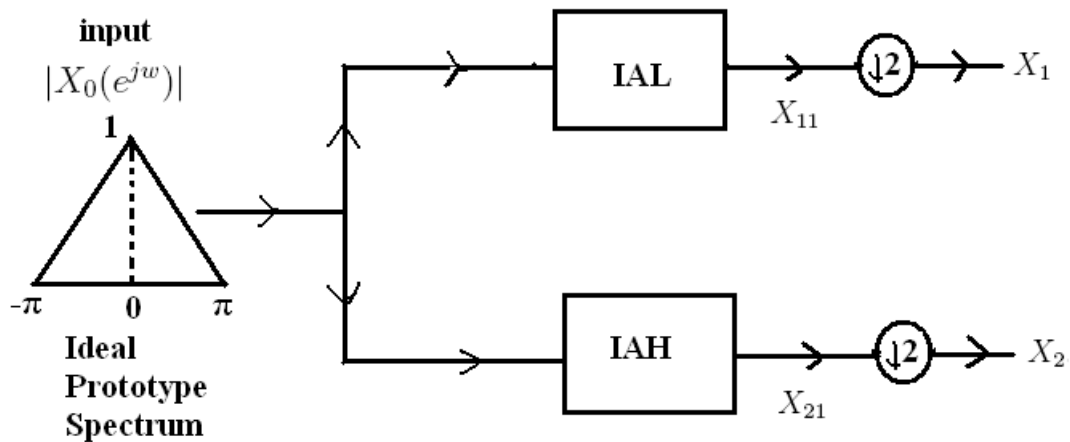

Figure 5: Ideal filter bank with prototype i/p spectrum

above filter bank structure with ideal prototype spectrum X_0 where we can see clearly the

spectrum at every point. The spectrums at points X_{11} and X_{21} are as shown in figure 6. Note that the spectrums X_{11} and X_{21} are periodic with period 2π .

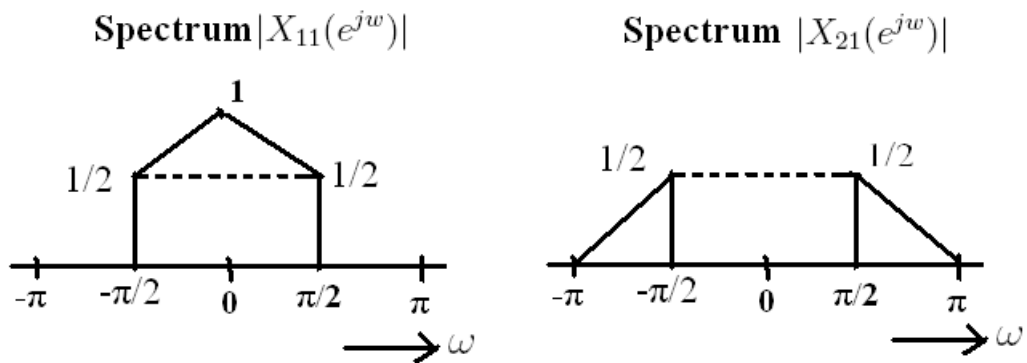

Figure 6: Spectrum at X_{11} and X_{21}

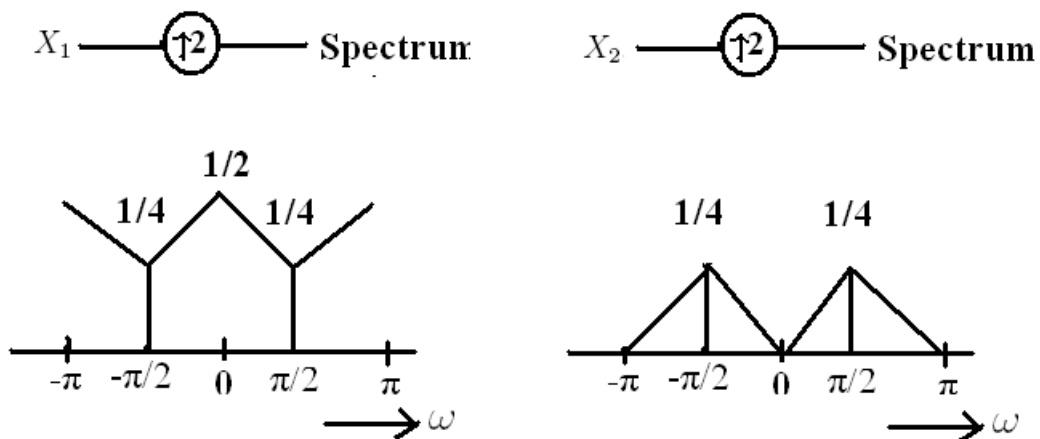

Figure 7: Upsampled spectrums of X_1 and X_2

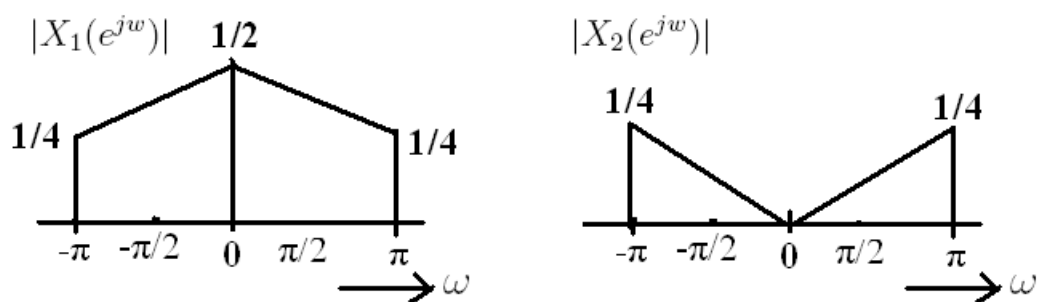

Figure 8: Spectrums at X_1 and X_2

Now there is an important point to emphasize at this stage that we need to do is to establish a correspondence between the segments of original spectrum X_0 and the spectra X_1 and X_2 . Let us divide the spectrum X_0 into four segments as

$$\alpha = (\pi/2 \Rightarrow \pi)$$

$$\beta = (0 \Rightarrow \pi/2)$$

$$\beta'' = (-\pi/2 \Rightarrow 0)$$

$$\alpha'' = (-\pi \Rightarrow -\pi/2)$$

The segments are marked as shown in figure-9 and corresponding segments are marked in X_1 and X_2 as shown in figure-10.

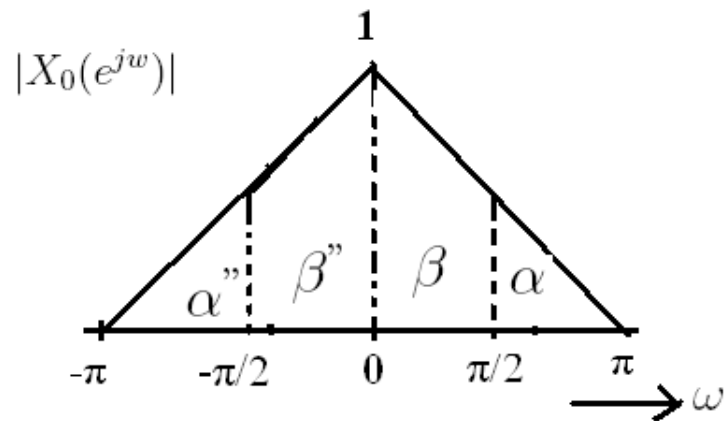

Figure 9: Segments of spectrum X_0

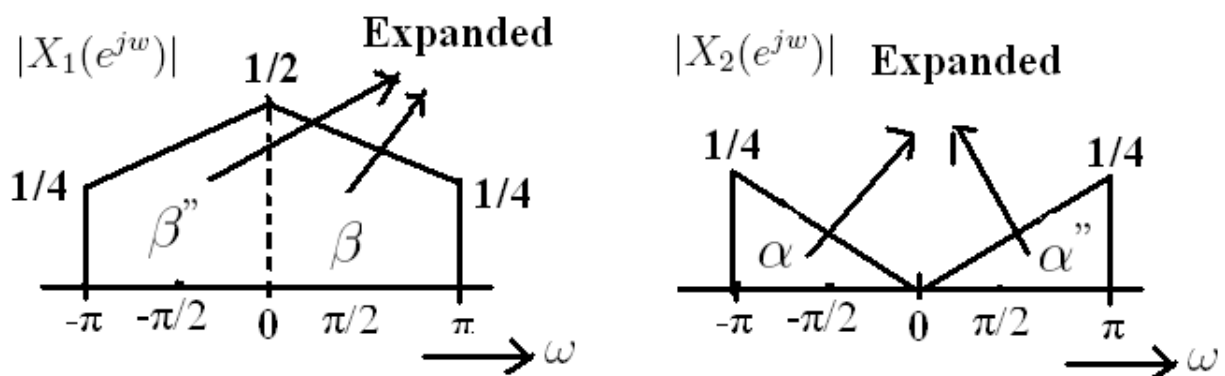

Figure 10: Segments of spectra X_1 and X_2

3 Notion of frequency inversion in highpass filtering

Frequency inversion means the reversal of order of frequencies. We notice that highpass segments α , α'' has gone to highpass branch, but there is a frequency inversion. In original input spectrum X_0 as we move from $\pi/2$ to π , correspondingly in X_2 we are moving from π to 0 whereas in original input spectrum X_0 as we move from 0 to $\pi/2$, correspondingly in X_1 we are moving 0 to π . The decomposition of input spectrum at each stage is shown figures 11 to 13. The figure 14 shows the summary of band distribution.

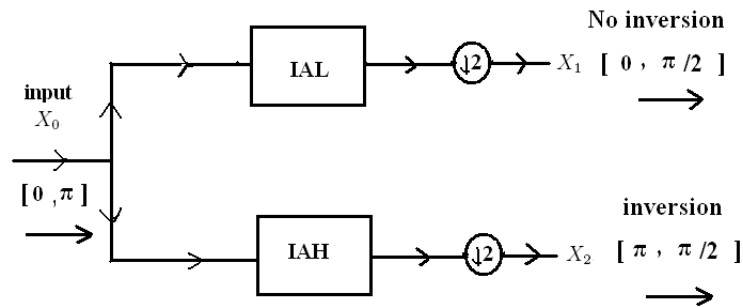

Figure 11: Decomposition of X_0

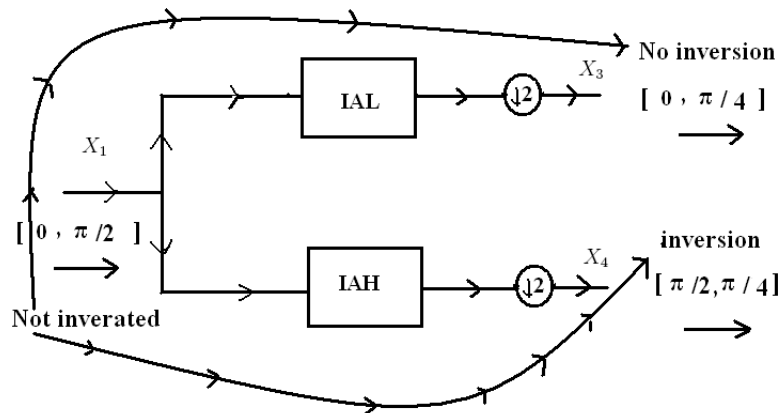

Figure 12: Decomposition of X_1

4 Reconstruction of input X_0 from wave packet transform

The reconstruction is not at all a problem, we can use the same ideal filters (i.e. not separate synthesis filters) as synthesis filters along with upsampling operations. Even if it is not ideal and if we have a perfect reconstruction synthesis filters then also reconstruction is possible. The reconstruction steps are as shown in figures 15, 16 and 17.

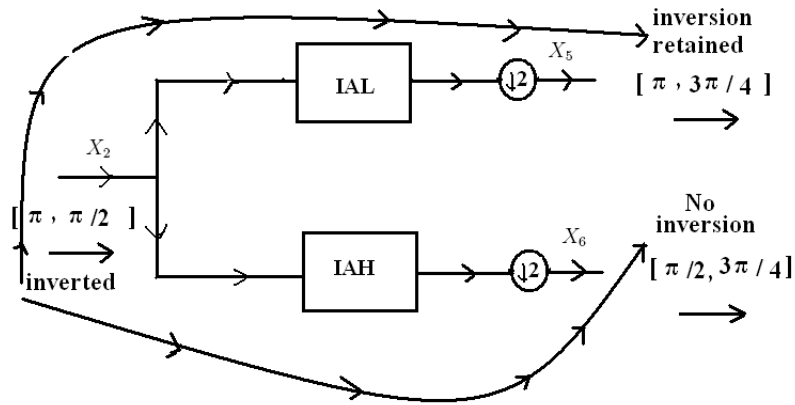

Figure 13: **Decomposition of X_2**

- X_3 : [0 , $\pi / 4$] \Rightarrow Not inverted
- X_4 : [$\pi / 2$, $\pi / 4$] \Rightarrow Inverted
- X_5 : [π , $3\pi / 4$] \Rightarrow Inverted
- X_6 : [$\pi / 2$, $3\pi / 4$] \Rightarrow Not inverted

Figure 14: **Band distribution of spectra X_3 to X_6**

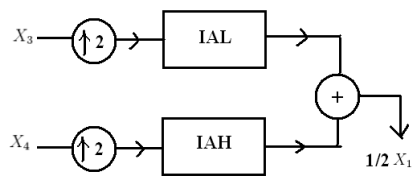

Figure 15: **Reconstruction of X_1**

Now let us see what happens if we apply this structure to Haar MRA, we need to look at it more carefully. We will consider the figure 18 to explain this in which the basis functions for respective subspaces are shown. If we decompose W_0 and W_1 as in wave packet transform marked by question mark in the figure below. Following are the few questions that need to be answered.

- 1] What are the basis functions for W_0 and W_1 ?
- 2] Can those basis functions obtained from a single function be called as generating function?

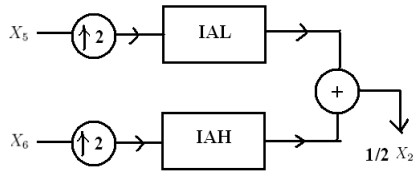

Figure 16: **Reconstruction of X_2**

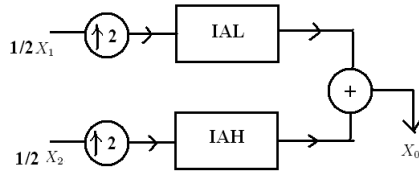

Figure 17: **Reconstruction of X_0**

3] Can we generalize this if we decompose the incremental subspaces?

We shall answer them in the next lecture.

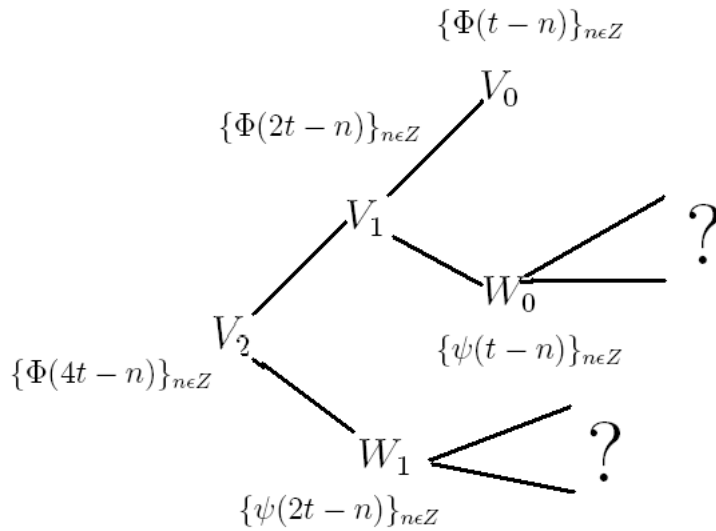

Figure 18: **Basis functions for decomposed subspaces**