

Module 2

Development of Equation of Motion for Nonlinear vibrating systems

In this module following points will be discussed for deriving the governing equation of motion of a system

- Force and moment based approach
 - Newton's 2nd Law
 - Generalized d'Alembert's Principle
- Energy based Approach
 - Lagrange Principle
 - Extended Hamilton's Principle
- Temporal equation using Galerkin's method for continuous system
- Ordering techniques, scaling parameters, book-keeping parameter
- Examples of Commonly used nonlinear equations: Duffing equation, Van der Pol's oscillator, Mathieu's and Hill's equations

Lecture M2 L01

Force and Momentum based Approach

In this approach one uses Newton's second law of motion or d'Alembert's principle to derive the equation of motion. This is a vector based approach in which first one has to draw the free body diagrams of the system and then write the force and moment equilibrium equations by considering the inertia force and inertia moment of the system.

According to Newton's second law when a particle is acted upon by a force it moves so that the force vector is equal to the time rate of change of the linear momentum vector.

Consider a body of mass m positioned at a distance r from the origin of the coordinate system XYZ as shown in Figure 2.1.1 is acted upon by a force F . According to Newton's 2nd Law, if the body has a linear velocity v , linear momentum vector $p = mv$, the external force is given by the following equation.

$$\vec{F} = \frac{d\vec{p}}{dt} = \frac{d(m\vec{v})}{dt} \quad (2.1.1)$$

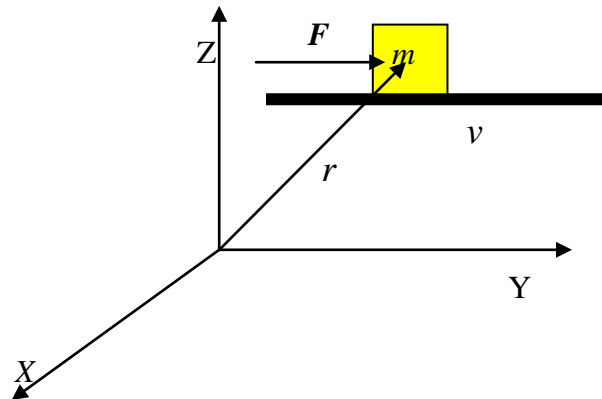

Figure 2.1.1: A body moving in XYZ plane under the action of a force F

Considering \vec{r} to be the absolute position vector of the particle in an inertial frame, the absolute velocity vector can be given by

$$\vec{v} = \frac{d\vec{r}}{dt} = \dot{\vec{r}} \quad (2.1.2)$$

the absolute acceleration vector is given by

$$\vec{a} = \frac{d^2\vec{r}}{dt^2} = \ddot{\vec{r}} \quad (2.1.3)$$

Assuming mass to be time invariant,

$$\text{Hence } \vec{F} = \frac{d}{dt} \left(m \frac{d\vec{r}}{dt} \right) = m \frac{d^2\vec{r}}{dt^2} = m\vec{a} \quad (2.1.4)$$

Equation (2.1.4) can also be written as , $\vec{F} - m\vec{a} = 0$ or, $\vec{F} + \vec{F}_i = 0$ where $\vec{F}_i = -m\vec{a}$ is the inertia force. This is d' Alembert's principle which states that a moving body can be brought to equilibrium by adding inertia force \vec{F}_i to the system. In magnitude this inertia force is equal to the product of mass and acceleration and takes place in a direction opposite to that of acceleration. Now two examples are given below to show the application of Newton's 2nd law or d' Alembert's principle to derive the non linear equation of motion of some systems.

Example 2.1.1: Use Newton's 2nd law to derive equation of motion of a simple pendulum

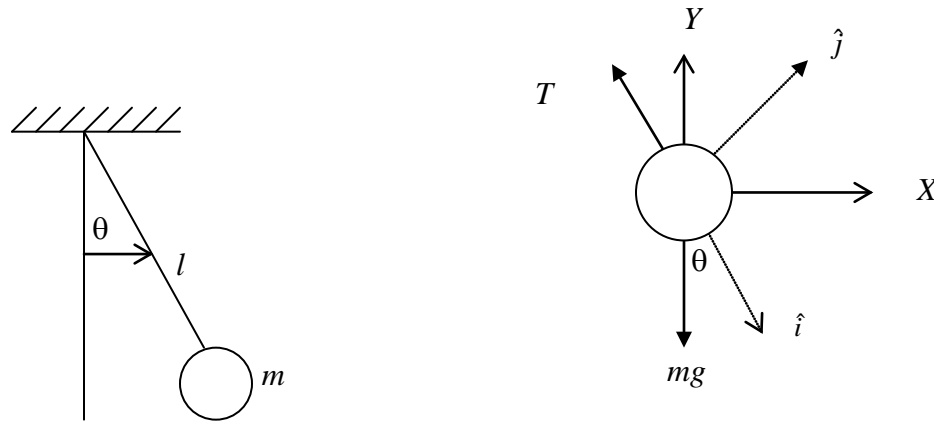

Figure 2.1. 2: (a) simple pendulum (b) Free body diagram

Solution: Figure 2.1.2 (a) shows a simple pendulum of length l and mass m and Figure 2.1.2(b) shows the free body diagram of the system. The acceleration of the pendulum can be given by $l\ddot{\theta}\hat{j} - l\dot{\theta}^2\hat{i}$. From the free body diagram total external force acting on the mass is given by

$$\vec{F} = (-T + mg \cos \theta)\hat{i} - mg \sin \theta \hat{j} \quad (2.1.5)$$

Now using Newton's second law's of motion i.e., $\vec{F} = m\vec{a}$

$$\vec{F} = (-T + mg \cos \theta)\hat{i} - mg \sin \theta \hat{j} = m(l\ddot{\theta}\hat{j} - l\dot{\theta}^2\hat{i}) \quad (2.1.6)$$

Now equating the real and imaginary parts one can get the equation of motion and the expression for the tension. The equation of motion is given by

$$ml\ddot{\theta} + mg \sin \theta = 0 \text{ or } \ddot{\theta} + \frac{g}{l} \sin \theta = 0 \quad (2.1.7)$$

and the expression for tension can be given by

$$T = mg \cos \theta + ml\dot{\theta}^2 = m(l\dot{\theta}^2 + g \cos \theta) \quad (2.1.8)$$

Taking $\sin \theta = \theta - \frac{\theta^3}{3!} + \frac{\theta^5}{5!} - \frac{\theta^7}{7!} \dots$, the nonlinear equation of motion of the system up to 7th order nonlinear term can be given by

$$\ddot{\theta} + \frac{g}{l} \left(\theta - \frac{\theta^3}{3!} + \frac{\theta^5}{5!} - \frac{\theta^7}{7!} + \dots \right) = 0 \quad (2.1.9)$$

$$\text{Or, } \ddot{\theta} + \frac{g}{l} \left(\theta - \frac{\theta^3}{6} + \frac{\theta^5}{120} - \frac{\theta^7}{5040} + \dots \right) = 0 \quad (2.1.10)$$

It may be noted that for higher power of θ , the coefficient become very small and hence the higher order terms can be neglected.

Keeping up to 5th order, the equation can be written as

$$\ddot{\theta} + \frac{g}{l} \left(\theta - \frac{\theta^3}{6} + \frac{\theta^5}{120} \right) = 0 \quad (2.1.11)$$

which is a form of Duffing equation with cubic and quintic nonlinearities.

One may derive the same equation using the fact that the moment of a force about a fixed point M_0 is equal to the time rate of change of the angular momentum about poin \dot{H}_0 . In mathematical form it can be written as $\vec{M}_0 = \dot{\vec{H}}_0$. Refereeing to Figure 2.1.2(b)

$$M_0 = \vec{r} \times \vec{F} \quad (2.1.12)$$

$$\text{Or, } \vec{M}_0 = (l\hat{i}) \times \left[(mg \cos \theta - T)\hat{i} - mg \sin \theta \hat{j} \right] \quad (2.1.13)$$

$$\text{Now, } \dot{\vec{H}}_0 = \frac{d}{dt} (ml^2 \dot{\theta}) \hat{k} = ml^2 \ddot{\theta} \hat{k} \quad (2.1.14)$$

$$\text{Or, } -mgl \sin \theta \hat{k} = ml^2 \ddot{\theta} \hat{k} \quad (2.1.15)$$

$$\text{Or, } ml^2 \ddot{\theta} + mgl \sin \theta = 0 \quad (2.1.16)$$

$$\text{Or, } \ddot{\theta} + \frac{g}{l} \sin \theta = 0 \quad (2.1.17)$$

Keeping up to cubic nonlinearity Eq. (2.1.17) can be written as

$$\ddot{\theta} + \frac{g}{l} \theta - \frac{g}{l} \frac{\theta^3}{6} = 0 \quad (2.1.18)$$

Taking the length of the pendulum 1 m and acceleration due to gravity as 10 m/s² the equation of motion can be written as

$$\ddot{\theta} + 10\theta - 1.6667\theta^3 = 0 \quad (2.1.19)$$

It may be noted that the coefficient for the cubic order term is very less than that of the linear term. A MatLab code is given below to obtain the variation of restoring force

with θ which will give an idea regarding the approximation one has to take while writing the equation of motion.

The equation is similar to a Duffing equations with soft type cubic nonlinearity.

Matlab code for restoring force plot

```
%Plot for restoring Force of a simple pendulum
% Written by S. K. Dwivedy on 30th May 2012
% th= theta
%L= length of pendulum

L=1;
g=9.8;

th=-pi:pi/100:pi;
f=(g/L)*(th-(1/factorial(3))*th.^3); %upto cubic order
f3=(g/L)*sin(th); % Actual
f1=10*th; % linear approximation
f5=(g/L)*(th-(1/factorial(3))*th.^3+(1/120)*th.^5); %uto quintic order
f7=f5-(g/L)*(1/factorial(7))*th.^7; %uto 7th order

plot(th,f,th,f1,'r',th,f3,'v',th,f5,'g',th,f7,'b')
grid on

xlabel('\theta')
ylabel('Restoring force')
```

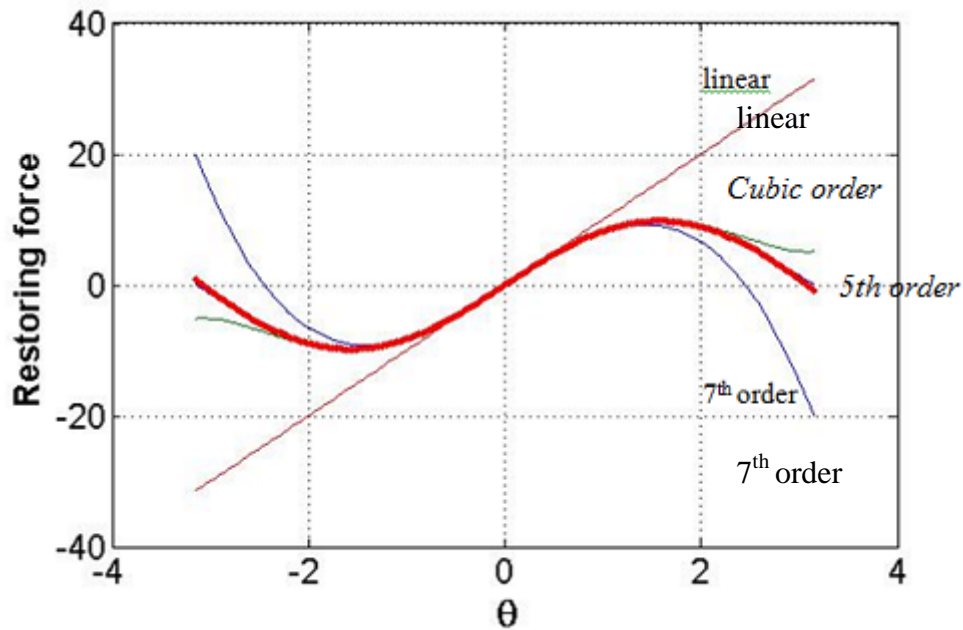

Fig. 2.1.3: Different approximation of the restoring force.

Figure 2.1.3 shows the restoring force for actual, linear, cubic, 5th order and 7th order approximation. It may clearly be noted that depending on the range of θ one may take the approximation accordingly.

Example 2.1.2: Derive equation of motion for a nonlinear spring-mass-damper system as shown below. Consider the spring force in the form of $f_s = kx + \alpha x^3$ and damping force equal to $f_d = c\dot{x} + \beta \dot{x}^2$

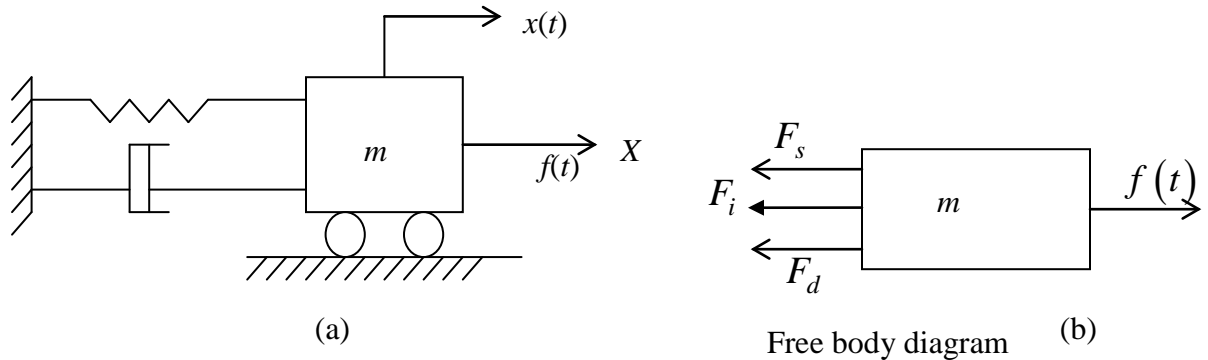

Figure 2.1.4 (a) Nonlinear spring-mass-damper system (b) free body diagram

Solution: Taking unit vector along positive X direction as \hat{i} , if a small displacement $x(t)$ is given to the mass m , as shown in Fig. 2.1.4(b), spring force, damping force and inertia force will act in a direction opposite to that of the external force $f(t)$. Now applying d' Alembert's principle one can write the following equation.

$$\sum \vec{F} + \vec{F}_i = f(t)\hat{i} - (F_s + F_d + F_i)\hat{i} = 0 \quad (2.1.20)$$

$$\text{Or, } f(t) - kx - \alpha x^3 - c\dot{x} - \beta \dot{x}^2 - m\ddot{x} = 0 \quad (2.1.21)$$

$$\text{Or, } m\ddot{x} + c\dot{x} + kx + \alpha x^3 + \beta \dot{x}^2 = f(t) \quad (2.1.22)$$

Example 2.1.3: Derive the equation of motion of a pendulum of length l mass m which is attached to a mass less moving support as shown in Figure 2.1.5.

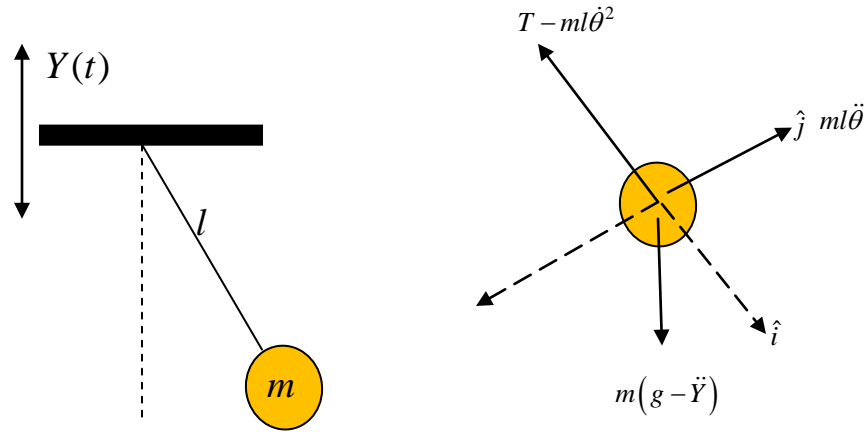

Figure 2.1.5: (a) Simple pendulum attached to a periodically translating support, (b) free body diagram of the mass.

Solution: Considering the free body diagram as shown in Fig. 2.1.5 (b), the body is under dynamic equilibrium under the action of tension, apparent weight and inertia force. Fixing unit vector \hat{i} and \hat{j} as shown in Figure 2.1.5(b) and applying Newton's 2nd Law one can write

$$\vec{F} = (-T + m(g - \ddot{Y}) \cos \theta) \hat{i} - m(g - \ddot{Y}) \sin \theta \hat{j} = m(l\ddot{\theta} \hat{j} - l\dot{\theta}^2 \hat{i}) \quad (2.1.23)$$

Separating the i^{th} and j^{th} component of the forces and equating them to 0 one obtains the expression for the tension and the governing equation of motion as given below.

$$T = m(g - \ddot{Y}) \cos \theta + ml\dot{\theta}^2 \quad (2.1.24)$$

$$-m(g - \ddot{Y}) \sin \theta = ml\ddot{\theta} \quad (2.1.25)$$

$$\text{Or, } \ddot{\theta} + \left(\frac{g}{l} - \frac{\ddot{Y}}{l} \right) \sin \theta = 0 \quad (2.1.26)$$

Taking the oscillation to be very small, $\sin \theta \approx \theta$ and hence Eq.(2.1.26) reduces to

$$\ddot{\theta} + \frac{g}{l} \theta - \frac{\ddot{Y}(t)}{l} \theta = 0 \quad (2.1.27)$$

It may be noted from the 3rd term in Eq. (2.1.27) that the coefficient of the response θ is a time varying parameter. Hence this type of system is known as parametrically excited system and this equation is known as Mathieu-Hill type of equation. Taking cubic order nonlinear term, this equation will become the equation of a parametrically excited system with cubic nonlinearities.

$$\ddot{\theta} + \left[\frac{g}{l} - \frac{Y(t)}{l} \right] \left(\theta - \frac{\theta^3}{6} \right) \quad (2.1.28)$$

Exercise Problems

Problem 2.1.1 Derive the equation motion of a compound pendulum.

Problem 2.1.2 Derive the equation of motion a tuned vibration absorber considering the primary spring force equal to $F_s = k_1 x + k_2 x^3$

Problem 2.1.3 Derive the equation motion of the following system. Consider the spring to be a nonlinear spring having the spring force $F_s = K(x - \varepsilon x^3)$. Assume other elements to be linear.

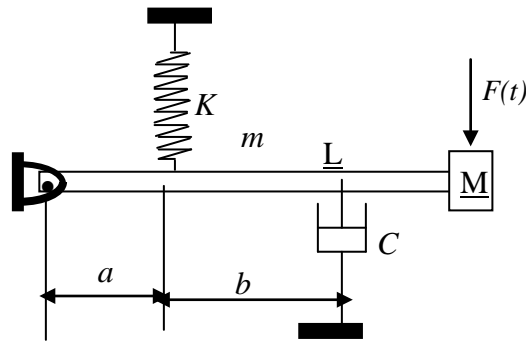

Figure 2.1.6 System for exercise problem 2.1.3.

Lecture M 2 L02

Derivation of Equation of motion for Multi-degree of freedom systems

In this lecture the nonlinear governing equation of motions of multi-degree of freedom nonlinear systems will be derived by using Newton's 2nd Law or d'Alembert's principle. The approach is similar to that of the single degree of freedom system. One can derive the equation of motion by drawing the free body diagrams and then writing the force or moment equilibrium equations by including the inertia force. Let us consider following simple examples to derive the equation of motions.

Example 2.2.1: Derive the equation motion of system shown in Fig. 2.2.1. Consider the last spring to be nonlinear where the spring force is given by $F_s = k_3x + k_4x^2$. Consider other spring and damper behaviour to be linear.

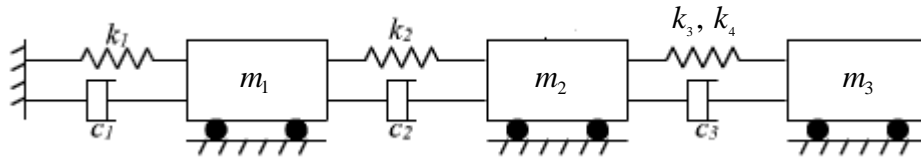

Figure 2.2.1. A multi degree of freedom system

Solution

Considering the equilibrium of the mass m_1 ,

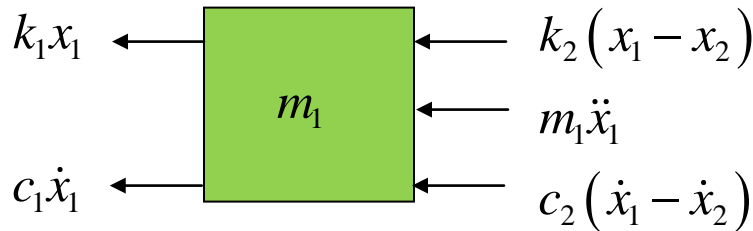

Figure 2.2.2: Free body diagram of part with mass m_1

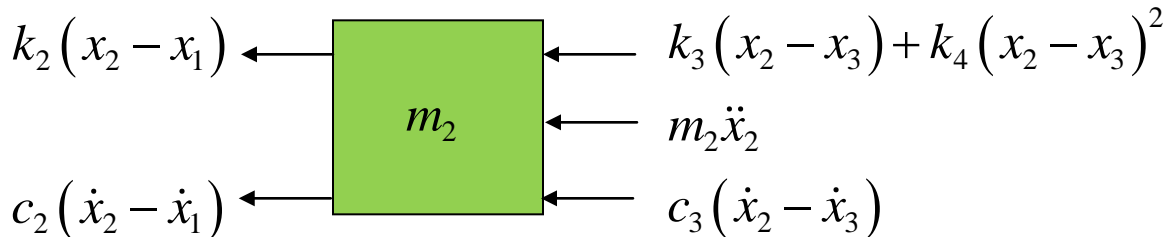

Figure 2.2.3: Free body diagram of part with mass m_2

Equating the forces acting on mass m_1 as shown in Fig. 2.2.2 one obtains

$$m_1 \ddot{x}_1 + k_1 x_1 + c_1 \dot{x}_1 + k_2 (x_1 - x_2) + c_2 (\dot{x}_1 - \dot{x}_2) = 0. \quad (2.2.1)$$

Similarly considering the free body diagram for the 2nd mass the equation of motion can be written as

$$m_2 \ddot{x}_2 + k_2 (x_2 - x_1) + c_2 (\dot{x}_2 - \dot{x}_1) + k_4 (x_2 - x_3) + k_3 (x_2 - x_3)^2 + c_3 (\dot{x}_2 - \dot{x}_3) \quad (2.2.2)$$

From the free body diagram shown in Fig. 2.2.4, the equation of motion for the 3rd mass can be given by

$$m_3 \ddot{x}_3 + k_3 (x_3 - x_2) + k_4 (x_3 - x_2)^2 + c_3 (\dot{x}_3 - \dot{x}_2) = 0 \quad (2.2.3)$$

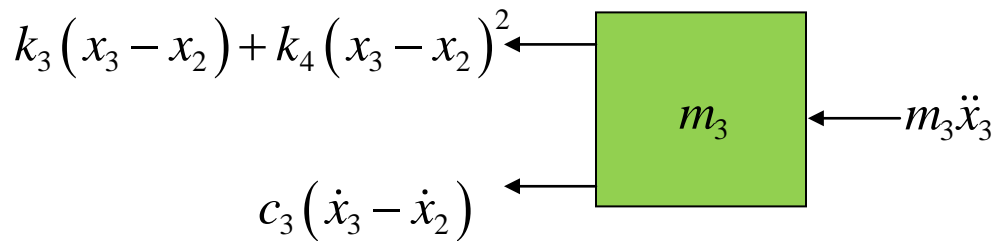

Figure 2.2.4: Free body diagram of part with mass m_2

It may be noted that as the last spring is connected to both second and third masses, the obtained second and third equations are nonlinear. So the equation of motions of the system can be written as

$$m_1 \ddot{x}_1 + k_1 x_1 + c_1 \dot{x}_1 + k_2 (x_1 - x_2) + c_2 (\dot{x}_1 - \dot{x}_2) = 0 \quad (2.2.4)$$

$$m_2 \ddot{x}_2 + k_2 (x_2 - x_1) + c_2 (\dot{x}_2 - \dot{x}_1) + k_3 (x_2 - x_3) + k_4 (x_2 - x_3)^2 + c_3 (\dot{x}_2 - \dot{x}_3) = 0 \quad (2.2.5)$$

$$m_3 \ddot{x}_3 + k_3 (x_3 - x_2) + k_4 (x_3 - x_2)^2 + c_3 (\dot{x}_3 - \dot{x}_2) = 0 \quad (2.2.6)$$

Exercise Problems:

Prob. 2.2.1: Derive the equation of motion of the nonlinear vibration absorber as shown in Fig. 2.2.3. Consider spring k_1 and k_2 to be nonlinear with linear, quadratic and cubic nonlinear coefficients. [Ref: Y.A. Amer, A.T. EL-Sayed, Vibration suppression of nonlinear system via non-linear absorber, Communications in Nonlinear Science and Numerical Simulation, Volume 13, Issue 9, November 2008, Pages 1948-1963]

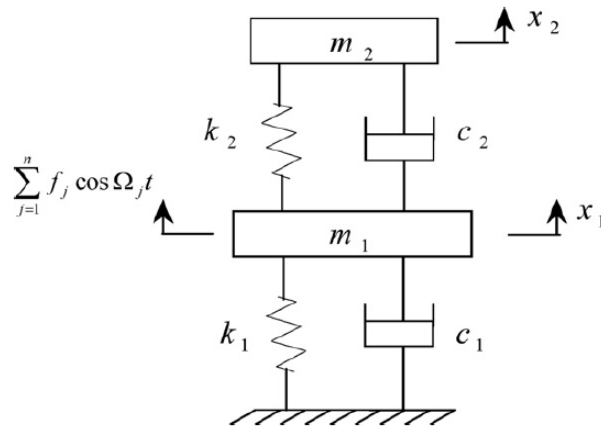

Figure 2.2.5: Nonlinear Vibration absorber.

Answer:

$$\begin{aligned}
 m_1 \ddot{x}_1 + c_1 \dot{x}_1 + c_2 \dot{x}_1 x_1^2 + k_{11} x_1 + k_{12} x_1^2 + k_{13} x_1^3 + c_3 (\dot{x}_1 - \dot{x}_2) + k_{21} (x_1 - x_2) \\
 + k_{22} (x_1 - x_2)^2 + k_{23} (x_1 - x_2)^3 = \sum_{j=1}^n f_j \cos \Omega_j t \\
 m_2 \ddot{x}_2 + c_3 (\dot{x}_2 - \dot{x}_1) + k_{21} (x_2 - x_1) + k_{22} (x_2 - x_1)^2 + k_{23} (x_2 - x_1)^3 = 0
 \end{aligned} \tag{2.2.7}$$

Prob. 2.2.2: Find the equation of motion of the following system which models the vibration control of ultrasonic cutting via dynamic absorber [Ref: Y.A. Amer, Vibration control of ultrasonic cutting via dynamic absorber, Chaos, Solitons & Fractals, Volume 33, Issue 5, August 2007, Pages 1703-1710]

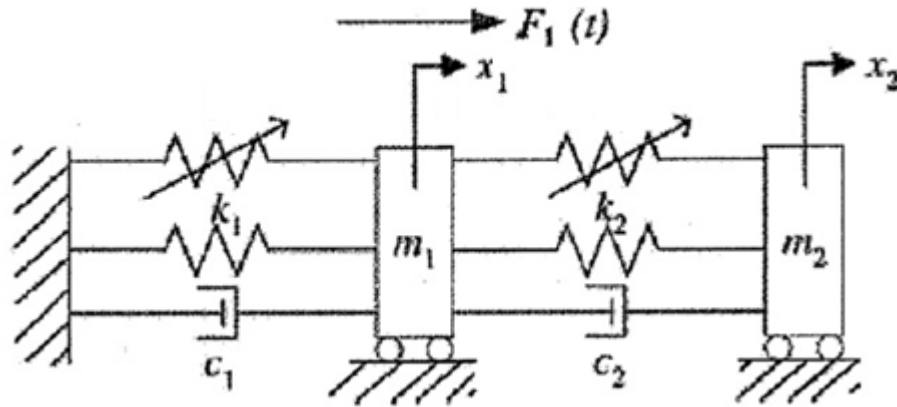

Figure 2.2.6: System for vibration control of ultrasonic cutting via dynamic absorber.

Prob. 2.2.3: Derive the equation of motion of a two stage gear system with mesh stiffness fluctuation, bearing flexibility and backlash [Ref: Lassâad Walha, Tahar Fakhfakh, Mohamed Haddar, Nonlinear dynamics of a two-stage gear system with mesh stiffness fluctuation, bearing flexibility and backlash, Mechanism and Machine Theory, Volume 44, Issue 5, May 2009, Pages 1058-1069]

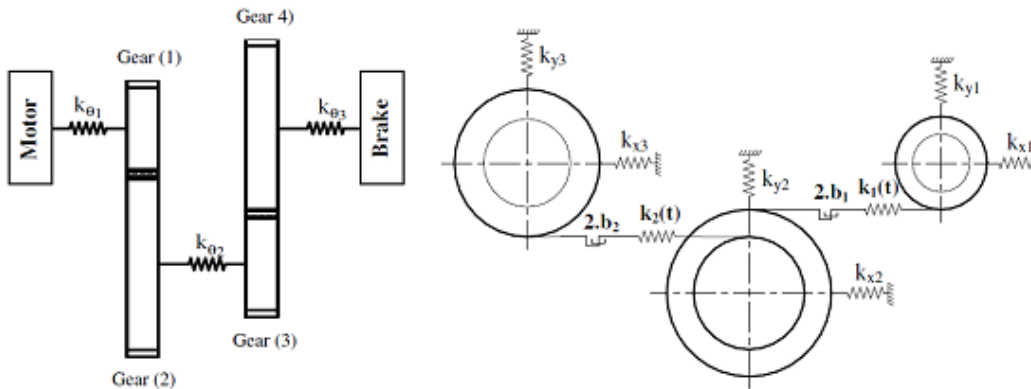

Figure 2.2.7: Two stage gear considering nonlinear coupling

Prob. 2.2.4: Derive the equation of motion of a pair of spur gear considering backlash. The system is shown in Fig. 2.2.7 [Ref: Hamed Moradi, Hassan Salarieh, Analysis of nonlinear oscillations in spur gear pairs with approximated modelling of backlash nonlinearity, Mechanism and Machine Theory, Volume 51, May 2012, Pages 14-31]

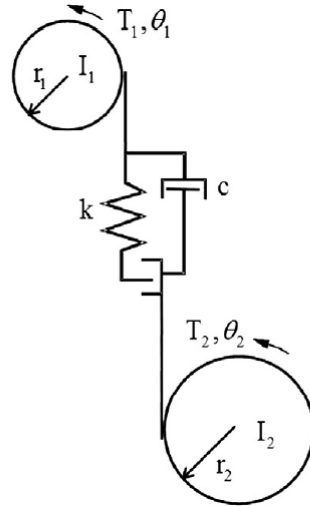

Figure 2.2.8: Modeling of a pair of spur gear considering backlash

Answer:

$$\begin{aligned}
 I_1 \ddot{\theta}_1 + c r_1 (r_1 \dot{\theta}_1 - r_2 \dot{\theta}_2) + k r_1 (r_1 \theta_1 - r_2 \theta_2) &= T_1 \\
 I_2 \ddot{\theta}_2 + c r_2 (r_1 \dot{\theta}_1 - r_2 \dot{\theta}_2) - k r_2 (r_1 \theta_1 - r_2 \theta_2) &= T_2
 \end{aligned}
 \tag{2.2.8}$$

Lecture M 2 L03

Derivation of the equation of motion of continuous system using d'Alembert's principle.

In this lecture, with help of example we will derive the governing equation of motion of a continuous or distributed mass system using d'Alembert's principle. It may be noted that in previous two lectures we considered discrete system in which the governing equation of motions are in the form of ordinary differential equations. But in continuous system the governing equations are in the form of partial differential equation as the state vector (e.g., displacement) depends not only on time but also on the space co-ordinates. For example in case of axial vibration of a bar the axial displacement of the bar depends on the time and location of the point on the bar at which the displacement has to be measured. Also, it may be noted that, unlike discrete system where the natural frequencies of the system has a definite value, in case of continuous system the system has infinite number of natural frequencies. Depending on particular applications, one may convert the analysis of continuous system to that of a multi-degree of freedom system by considering finite participating modes in the analysis.

Example 2.3.1: Figure 2.3.1 shows a roller-supported base excited cantilever beam with tip mass. In practical application it can be a single-link flexible Cartesian manipulator with a payload of mass M . The left end of the manipulator is roller-supported which is subjected to harmonically varying support motion $Y_b(t) = Z \cos \Omega_1 t$. The right end of the manipulator is subjected to a sinusoidally varying axial force $P(t) = P_0 + P_1 \cos \Omega_2 t$. The motion of the manipulator is considered to be in the vertical plane. Derive the governing equation of motion using d'Alembert's principle.

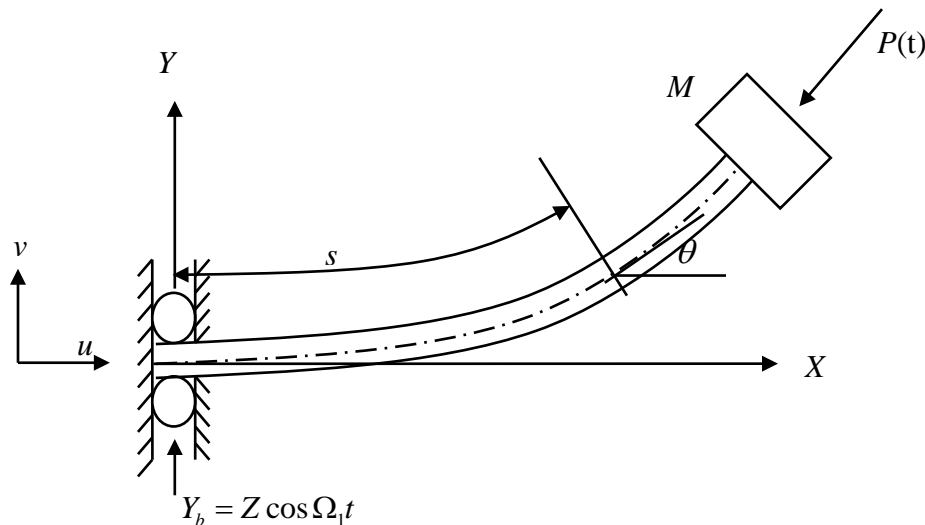

Figure 2.3.1 Schematic diagram of a single-link Cartesian manipulator with payload subjected to harmonically varying axial force.

Solution:

Here, the Cartesian manipulator with payload is modeled as a roller-supported Euler–Bernoulli beam with a tip mass. The thickness (h) of the beam is considered to be very small in comparison to the length of the beam (L). Hence, the effects of the shear deformation and rotary inertia of the beam are neglected. The transverse vibration (v) of the beam is assumed to be purely planar. The torsional mode of the beam is neglected in this analysis. Payload mass is considered as a point mass which is symmetrically placed with respect to the centerline of the beam. The harmonically varying tip load is acting always in the tangential direction of the elastic line and the amplitude of the axial force is taken less than the critical buckling load.

The governing equation of motion of the present system is derived using d’Alembert’s principle. Considering a small element at a distance s from the roller-supported end (Fig.2 3.1) along the elastic line of the beam, the bending moment $M(s)$ of the beam can be expressed as:

$$M(s) \approx EI \left(v_{ss} + \frac{1}{2} v_s^2 v_{ss} \right). \quad (2.3.1)$$

Here, v is the transverse displacement of the beam. $()_s$ is the first derivative with respect to s along the beam. Following Zavodney and Nayfeh (1989), and Civalci (1996, 2000), one may write the inextensibility condition of the beam in terms of the longitudinal displacement $u(\xi, t)$ and the transverse displacement $v(\xi, t)$ as:

$$v_s^2 + (1 + u_s)^2 = 1. \quad \text{or, } u(\xi, t) = \xi - \int_0^\xi (1 - v_\eta^2)^{\frac{1}{2}} d\eta. \quad (2.3.2)$$

Here, ξ, η are the integration variables. Considering the inertia forces per unit length of the beam $\rho A \ddot{u}$, and $\rho A (\ddot{v} + \ddot{Y}_b)$, in longitudinal and transverse directions, respectively and inertia forces of the tip mass in longitudinal and transverse directions as $M \ddot{u}$ and $M (\ddot{v} + \ddot{Y}_b)$, respectively, one may write equation (2.3.1) as follows:

$$M(s) - M_\xi(s) - M_L(s) = 0. \quad (2.3.3)$$

Here, $M_\xi(s)$ is the moment due to inertia force at a distance ξ from the roller-supported end and $M_L(s)$ is the moment due to inertia force for the payload at the tip of the manipulator and their expressions are given below:

$$M_\xi(s) = -\int_s^L \rho A \ddot{u} \int_s^\xi \sin \theta d\eta d\xi - \int_s^L \rho A (\ddot{v} + \ddot{Y}_b) \int_s^\xi \cos \theta d\eta d\xi, \quad (2.3.4)$$

$$\text{and, } M_L(s) = -M \ddot{u} \int_s^L \sin \theta d\xi - M (\ddot{v} + \ddot{Y}_b) \int_s^L \cos \theta d\xi - P(t) \int_s^L \sin \theta d\xi. \quad (2.3.5)$$

Considering equivalent viscous damping force $c_d \dot{v}$ due to interaction of the system with the environment and by differentiating Eq. (2.3.3) twice with respect to s , using the Leibniz's rule and applying the binomial expansion, one may obtain the following governing differential equation of motion.

$$\begin{aligned} EI \left(v_{ssss} + \frac{1}{2} v_s^2 v_{ssss} + 3v_s v_{ss} v_{sss} + v_{ss}^3 \right) + \rho A v_s \left(\int_0^s (\dot{v}_\xi^2 + v_\xi \ddot{v}_\xi) d\xi \right) + M (\ddot{v} + \ddot{Y}_b) v_s v_{ss} + v_s v_{ss} \\ \left(\rho A \ddot{Y}_b (L-s) + \int_s^L (\rho A \ddot{v} + c_d \dot{v}) d\eta \right) - v_{ss} \left(\int_s^L \rho A \int_0^\xi (\dot{v}_\zeta^2 + v_\zeta \ddot{v}_\zeta) d\xi d\eta + M \int_0^s (\dot{v}_\zeta^2 + v_\zeta \ddot{v}_\zeta) d\xi \right) + \\ \left(1 - \frac{1}{2} v_s^2 \right) (\rho A (\ddot{v} + \ddot{Y}_b) + c_d \dot{v}) + (P(t) v_s)_s = 0. \end{aligned} \quad (2.3.6)$$

Example- 2.3.2

Derive the equation motion of a string fixed at one end and attached by a nonlinear spring at the other end.

Solution

$$\begin{aligned} \left[T(x) + \frac{\partial T(x)}{\partial x} dx \right] \left[\frac{\partial w(x,t)}{\partial x} + \frac{\partial^2 w(x,t)}{\partial x^2} dx \right] + f(x,t) dx - T(x) \frac{\partial w(x,t)}{\partial x} \\ = \rho(x) dx \frac{\partial^2 w(x,t)}{\partial t^2}, \quad 0 < x < L \end{aligned} \quad (2.3.7)$$

$$\frac{\partial}{\partial x} \left[T(x) \frac{\partial w(x,t)}{\partial x} \right] + f(x,t) = \rho(x) dx \frac{\partial^2 w(x,t)}{\partial t^2}, \quad 0 < x < L \quad (2.3.8)$$

Subjected boundary conditions

$$w(x,t) = 0, \text{ at } x = 0 \text{ and } T(x) \frac{\partial w(x,t)}{\partial x} + K_1 w(x,t) + K_2 w^3(x,t) = 0, \text{ at } x = L \quad (2.3.9)$$

Equation (2.3.8) is partial differential equation of motion and (2.3.9) are the boundary conditions.

To develop different nonlinear equations of motion for string systems, one may refer the following papers on nonlinear vibration of strings.

1. G.S.S. Murthy, B.S. Ramakrishna, Non-linear character of resonance in stretched strings, *J. Acoust. Soc. Am.*, 38 (1965), p. 461
2. J.W. Miles, Stability of forced oscillations of a vibrating string, *J. Acoust. Soc. Am.*, 38 (1965), p. 855
3. G.V. Anand, Non-linear resonance in stretched strings with viscous damping, *J. Acoust. Soc. Am.*, 40 (1966), p. 1517.
4. E.W. Lee, Non-linear forced vibration of a stretched string, *Br. J. Appl. Phys.*, 8 (1957), p. 411
5. D.W. Oplinger, Frequency response of a non-linear stretched string, *J. Acoust. Soc. Am.*, 32 (1960), p. 1529
6. G.F. Carrier, On the non-linear vibration problem of the elastic string, *Q. Appl. Math.*, 3 (1945), p. 157

Exercise Problems

Prob. 2.3.1. Derive the equation of motion of a base excited cantilever with an attached mass at arbitrary position as shown in Fig. 2.3.2. (Ref: Zavodney and Nayfeh(1989),

Prob.2.3.2: Derive the equation of motion of a dynamic vibration absorber as shown in Figure 2.3.3.

Prob. 2.3.3: Derive the equation motion of the moving belt system shown in Fig. 2.3.4 [C.A. Jones, P. Reynolds, A. Pavic, *Vibrational power flow in the moving belt passing through a tensioner*, *Journal of Sound and Vibration*, Volume 330, Issue 8, 2011, Pages 1531-156]

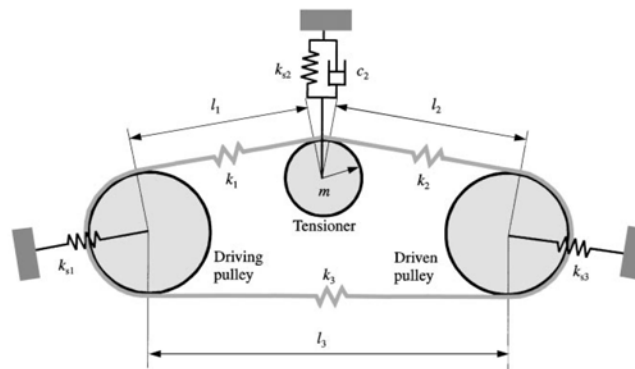

Answer:

$$\rho A \frac{\partial^2 w}{\partial t^2} + 2\rho A c \frac{\partial^2 w}{\partial t \partial x} + (\kappa_i \rho A c^2 - R_0) \frac{\partial^2 w}{\partial x^2} + \beta c \frac{\partial w}{\partial t} + \beta \frac{\partial w}{\partial x} + EI \frac{\partial^4 w}{\partial x^4} = 0,$$

Lecture M2 L04

Derivation of equation of motion using Extended Hamilton's Principle

The purpose of this lecture is to use extended Hamilton's principle to derive the equation of motion of different systems. According to this method, for a system with kinetic energy T , potential energy U and virtual work done by the non-conservative force δW_{nc} , the governing equation motion can be obtained by using the following equation.

$$\int_{t_1}^{t_2} (\delta(T - U) + \delta W_{nc}) dt = 0, \quad \delta r_i(t_1) = \delta r_i(t_2) = 0, \quad i = 1, 2, \dots, n \quad (2.4.1)$$

Here, t_1 and t_2 are the time at which it is assumed that the virtual displacements δr_i for a system represented by n physical co-ordinates (r_i) vanishes. Using Lagrangian ($L = T - U$) and m generalized co-ordinates q_i of the system, the above equation can be written as

$$\int_{t_1}^{t_2} (\delta L + \delta W_{nc}) dt = 0, \quad \delta q_i(t_1) = \delta q_i(t_2) = 0, \quad i = 1, 2, \dots, m \quad (2.4.2)$$

Equation (2.4.1) and (2.4.2) are the equation for **Extended Hamilton's principle**. For a conservative system as $\delta W_{nc} = 0$, Eq. (2.4.2) reduces to

$$\int_{t_1}^{t_2} \delta L dt = 0, \quad \delta q_k(t_1) = \delta q_k(t_2) = 0 \quad (2.4.3)$$

which is known as the Hamilton's Principle.

This method is particularly useful for continuous systems where one can obtain both governing equation of motion and boundary conditions of the system.

Let us derive the equation of motion of few linear and nonlinear systems to get familiarize with the application of this method.

Example 2.4.1: Derive the equation of motion of a simple pendulum using extended Hamilton's principle.

Solution: In this case the kinetic energy T and potential energy U of the system can be given by

$$T = \frac{1}{2} m (l\dot{\theta})^2, \quad U = mgl(1 - \cos \theta) \quad (2.4.4)$$

$$\text{So, } L = T - U = \frac{1}{2} m (l\dot{\theta})^2 - mgl(1 - \cos \theta) \quad (2.4.5)$$

Now, applying Hamilton's principle one can write

$$\int_{t_1}^{t_2} \delta L dt = 0, \quad \delta\theta(t_1) = \delta\theta(t_2) = 0 \quad (2.4.6)$$

$$\int_{t_1}^{t_2} \delta \left(\frac{1}{2} m (l\dot{\theta})^2 - mgl(1 - \cos\theta) \right) dt = 0,$$

$$\text{or, } \int_{t_1}^{t_2} \left(\frac{1}{2} m 2l(\dot{\theta}) \delta(\dot{\theta}) - mgl \sin\theta \delta\theta \right) dt = 0,$$

$$\text{or, } \int_{t_1}^{t_2} \left(ml^2 \dot{\theta} \frac{d}{dt}(\delta\theta) - mgl \sin\theta \delta\theta \right) dt = 0$$

$$\text{or, } \underbrace{ml^2 \dot{\theta} \delta\theta \Big|_{t_1}^{t_2}}_{=0} - \int_{t_1}^{t_2} (ml^2 \ddot{\theta} + mgl \sin\theta) \delta\theta dt = 0 \quad (2.4.7)$$

The first term (marked in red colour) tends to zero as $\delta\theta(t_1) = \delta\theta(t_2) = 0$. As the virtual displacement $\delta\theta$ is arbitrary, hence the coefficient of $\delta\theta dt$ term should vanish. Therefore one obtains

$$ml^2 \ddot{\theta} + mgl \sin\theta = 0 \quad (2.4.8)$$

as the equation of motion of the simple pendulum. Taking up to 5th order terms this equation can be written as

$$\ddot{\theta} + \frac{g}{l} \left(\theta - \frac{\theta^3}{6} + \frac{\theta^5}{120} \right) = 0 \quad (2.4.9)$$

Example 2.4.2: Derive the equation of motion for the transverse vibration of an Euler-Bernoulli beam with fixed-free boundary condition subjected to axial periodic load as shown in Fig. 2.4.1.

Solution:

Let us first derive the equation of motion of the system considering small displacement of the system.

The kinetic energy T of the beam can be given as follows:

$$T = \frac{1}{2} \int_0^L m w_{,t}^2 dx \quad (2.4.10)$$

where, m is the mass of the beam per unit length and $()_{,t}$ represents the differentiation with respect to time.



Fig: 2.4.1: Schematic diagram of a cantilever beam under transverse vibration due to application of a periodic axial load
 The potential energy of the system is due to the strain energy of the system and is given by

$$U = \frac{1}{2} \int_0^L EI w_{,xx}^2 dx \quad (2.4.11)$$

Hence the Lagrangian of the system $L = T - U = \frac{1}{2} \int_0^L m w_{,t}^2 dx - \frac{1}{2} \int_0^L EI w_{,xx}^2 dx \quad (2.4.12)$

Assuming inextensible beam condition, there will be no elongation in the axial direction along the neutral axis of the beam. The longitudinal deformation u of the beam due to transverse deformation w can be expressed as

$$\left(1 + \frac{du}{dx}\right)^2 + \left(\frac{dw}{dx}\right)^2 = 1 \quad (2.4.13)$$

Rearranging Eq. (2.4.13) and using a first order Taylor series expansion, the following relationship can be obtained.

$$u = -\frac{1}{2} \int_0^L \left(\frac{dw}{dx}\right)^2 dx \quad (2.4.14)$$

The work done due to the nonconservative axial force can be given by

$$\delta W_{nc} = -P \delta u = \frac{1}{2} P \delta \left(\int_0^L w'^2 dx \right) \quad (2.4.15)$$

Using Hamilton's principle

$$\int_{t_1}^{t_2} \delta (L + W_{nc}) dt = 0, \quad \delta w(t_1) = \delta w(t_2) = 0 \quad (2.4.16)$$

Using Eq (2.4.12) and Eq. (2.4.15) in Eq. (2.4.16) one can write

$$\int_{t_1}^{t_2} (\delta L + \delta W_{nc}) dt = \int_{t_1}^{t_2} \left[\delta \left(\frac{1}{2} \int_0^L m w_{,t}^2 dx - \frac{1}{2} \int_0^L EI w_{,xx}^2 dx \right) + \frac{1}{2} P \delta \left(\int_0^L w_{,x}^2 dx \right) \right] dt \quad (2.4.17)$$

$$\text{or, } \int_{t_1}^{t_2} \int_0^L m \left(\frac{\partial w}{\partial t} \right) \delta \left(\frac{\partial w}{\partial t} \right) dx dt - \int_{t_1}^{t_2} \left[\int_0^L \left(EI \left(\frac{\partial^2 w}{\partial x^2} \right) \delta \left(\frac{\partial^2 w}{\partial x^2} \right) - P \frac{\partial w}{\partial x} \delta \left(\frac{\partial w}{\partial x} \right) \right) dx \right] dt = 0 \quad (2.4.18)$$

$$\text{or, } \int_0^L \left[\int_{t_1}^{t_2} m \left(\frac{\partial w}{\partial t} \right) \frac{\partial}{\partial t} (\delta w) dt \right] dx - \int_{t_1}^{t_2} \left[\int_0^L \left(EI \left(\frac{\partial^2 w}{\partial x^2} \right) \frac{\partial}{\partial x} \left(\delta \left(\frac{\partial w}{\partial x} \right) \right) - P \frac{\partial w}{\partial x} \frac{\partial}{\partial x} (\delta w) \right) dx \right] dt \quad (2.4.19)$$

Using integration by parts Eq.(2.4.19) can be written as,

$$\begin{aligned} & \int_0^L m \left(\frac{\partial w}{\partial t} \right) \underbrace{\left(\delta w \right)_{t_1}^{t_2}}_{= 0 \text{ as per definition}} dx - \int_0^L \left[\int_{t_1}^{t_2} m \left(\frac{\partial^2 w}{\partial t^2} \right) \delta w dt \right] dx \\ & - \int_{t_1}^{t_2} \underbrace{\left[EI \left(\frac{\partial^2 w}{\partial x^2} \right) \left(\delta \left(\frac{\partial w}{\partial x} \right) \right)_0^L + EI \left(\frac{\partial^3 w}{\partial x^3} \right) (\delta w)_0^L - P \left(\frac{\partial w}{\partial x} \right) (\delta w)_0^L \right]}_{\text{Boundary conditions}} dt \\ & - \int_{t_1}^{t_2} \left(\int_0^L \left(EI \frac{\partial^4 w}{\partial x^4} + P \frac{\partial^2 w}{\partial x^2} \right) \delta w dx \right) dt = 0 \end{aligned} \quad (2.4.20)$$

$$- \int_{t_1}^{t_2} \underbrace{\left[EI \left(\frac{\partial^2 w}{\partial x^2} \right) \left(\delta \left(\frac{\partial w}{\partial x} \right) \right)_0^L + EI \left(\frac{\partial^3 w}{\partial x^3} \right) (\delta w)_0^L - P \left(\frac{\partial w}{\partial x} \right) (\delta w)_0^L \right]}_{\text{Boundary conditions}} dt$$

$$\text{Or, } - \int_{t_1}^{t_2} \int_0^L \underbrace{\left(m \left(\frac{\partial^2 w}{\partial t^2} \right) + EI \frac{\partial^4 w}{\partial x^4} + P \frac{\partial^2 w}{\partial x^2} \right)}_{=0, \text{ Equation of motion}} \delta w dx dt = 0 \quad (2.4.21)$$

As the virtual displacement δw is arbitrary, hence the right hand side of the equation will be zero only if

$$m \left(\frac{\partial^2 w}{\partial t^2} \right) + EI \frac{\partial^4 w}{\partial x^4} + P \frac{\partial^2 w}{\partial x^2} = 0 \quad (2.4.22)$$

which is the equation of motion of the system. The boundary conditions can be obtained from the term marked in blue colour in Eq. (2.4.21). Now taking the periodic axial load as

$P = P_0 + P_1 \cos \Omega t$, Eq. (2.4.22) can be written as

$$m \frac{\partial^2 w}{\partial t^2} + EI \frac{\partial^4 w}{\partial x^4} + (P_0 + P_1 \cos \Omega t) \frac{\partial^2 w}{\partial x^2} = 0 \quad (2.4.23)$$

Due to the presence of a periodic term (marked in pink colour) as the coefficient of the term containing the response (marked in blue colour), the system is a parametrically excited system.

Exercise Problems:

Problem 2.4.1: Derive the equation of motion of a cantilever beam subjected to magnetic field using extended Hamilton's principle.

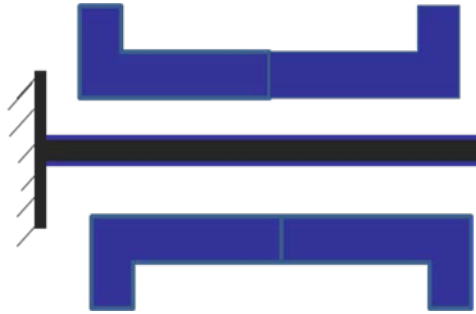

Fig. 2.4.2: Schematic diagram of a cantilever beam subjected to magnetic field.

Hints: The expression for kinetic and strain energy of the system can be taken similar to that taken in example 2.4.2.

$$T = \frac{1}{2} \int_0^L m w_{,t}^2 dx \quad (2.4.24)$$

$$(U_t)_{bending} = \frac{1}{2} \int_0^L E_t I_t w_{,xx}^2 dx \quad (2.4.25)$$

Considering conductive material, the magnetoelastic load applied to the beam is equivalent to the horizontal force n and the distributed moment m which are expressed in terms of the longitudinal displacement (u) and transverse displacement (w) as (Zhou and Wang [1]), Moon and Pao [2]

$$n = \frac{B_0^2 b h}{\mu_e} u_{,xx} \text{ and} \quad (2.4.26)$$

$$m^m = \frac{B_0^2 b h}{\mu_0} \left(\frac{\pi}{2 \ln \frac{x}{L-x}} u_{,x} - \frac{h}{2\pi} w_{,xx} \ln \frac{x}{L-x} + w_{,x} \right) - \frac{B_0^2 b h^3}{12 \mu_e} w_{,xxx}. \quad (2.4.27)$$

Here, μ_0 and μ_e are respectively the permeability of the free space and the beam materials.

The non-conservative work done due to the applied axial periodic load and the above mentioned magnetoelastic loads and moments can be given by

$$W_{nc} = \frac{1}{2} \int_0^L P w_{,x}^2 dx + \int_0^L \left[n_t \delta u_t + n_b \delta u_b + m_t^m \delta w_{,x} + m_b^m \delta w_{,x} \right] dx \quad (2.4.28)$$

Problem. 2.4.2: Derive the equation motion of a base excited cantilever beam with arbitrary mass position using extended Hamilton's principle. (Refer: Kar and Dwivedy 1999 for the derivation using d'Alembert's principle)

References for Further Reading

- [1] G. Y. Zhou, Q. Wang, Use of Magnetorheological Elastomer in an Adaptive Sandwich Beam with Conductive Skins. Part I: Magnetoelastic Loads in Conductive Skins, *International Journal of Solids and Structures* 43, 5386-5402, 2006.
- [2] F.C. Moon and Y. H. Pao, 1969, Vibration and dynamic instability of a beam-plate in a transverse magnetic field, *Journal of Applied Mechanics* 36, 92–100, 1969
- [3] R. C. Kar and S. K. Dwivedy, Non-linear dynamics of a slender beam carrying a lumped mass with principal parametric and internal resonances. *International Journal of Nonlinear Mechanics*, **34** (3)515-529, 1999.

Lecture M2 L05

Derivation of Equation of motion using Lagrange Principle

Both Hamilton's principle and Lagrange principle are based on energy principle for deriving the equation of motion of a system. As energy is a scalar quantity, the derivation of equation of motion is more straight forward unlike the derivation based on Newton's 2nd Law or d'Alembert's principle which are vector based approach. In the Newton's or d'Alembert's approach, with increase in degrees of freedom of the system it is very difficult and time consuming to draw the free body diagrams to find the equation of motion using force or moment equilibrium. Hence it is advantageous to go for energy based approach. While in Hamilton's principle one uses a integral based approach, in Lagrange principle a differential approach is followed. Hence, use of Lagrange principle is easier than the Hamilton's principle. Though all these methods in principle can be applied to any system, however it is better to use Newton's 2nd Law or d'Alembert's principle for single or two degree of freedom systems, Lagrange principle for multi degree of freedom and extended Hamilton's principle for continuous systems.

In Lagrange principle, generally the equations of motion are derived using generalized coordinates. Let us consider a system with N physical coordinates and n generalized coordinates. The kinetic energy T for a system of particles can be given by

$$T = T(r_1, r_2, \dots, r_N, \dot{r}_1, \dot{r}_2, \dots, \dot{r}_N) \quad (2.5.1)$$

Where r_i and \dot{r}_i are the position and velocity vector of a typical particles of mass m_i ($i=1,2,\dots, N$). Considering q_k and \dot{q}_k as the displacement and velocity in terms of k^{th} generalized coordinates, one may write,

$$\dot{r}_i = \sum_{k=1}^n \frac{\partial r_i}{\partial q_k} \dot{q}_k \quad (2.5.2)$$

So using generalized coordinate one may write,

$$T = T(q_1, q_2, \dots, q_n, \dot{q}_1, \dot{q}_2, \dots, \dot{q}_n) \quad (2.5.3)$$

$$\text{Hence, } \delta T = \sum_{k=1}^n \left(\frac{\partial T}{\partial q_k} \delta q_k + \frac{\partial T}{\partial \dot{q}_k} \delta \dot{q}_k \right) \quad (2.5.4)$$

The virtual work ($\overline{\delta W}$) performed by the applied force \vec{F}_i can be written in terms of generalized forces and virtual displacement or

$$\overline{\delta W} = \sum_{k=1}^n Q_k \delta q_k \quad (2.5.5)$$

$$\text{where, } Q_k = \sum \vec{F}_i \cdot \frac{\partial \vec{r}_i}{\partial q_k}, k = 1, 2, \dots, n. \quad (2.5.6)$$

The over bar in $\overline{\delta W}$ shows that the work done is a path function. Substituting (2.5.4) and (2.5.5) into the extended Hamilton's Principle,

$$\int_{t_1}^{t_2} (\delta T + \overline{\delta W}) dt = 0, \quad \delta q_k(t_1) = \delta q_k(t_2) = 0, \quad k=1,2,\dots,n \quad (2.5.7)$$

one obtains the following equation.

$$\int_{t_1}^{t_2} \left[\sum_{k=1}^n \left(\frac{\partial T}{\partial q_k} \delta q_k + \frac{\partial T}{\partial \dot{q}_k} \delta \dot{q}_k \right) + \sum_{k=1}^n Q_k \delta q_k \right] dt = 0 \quad (2.5.8)$$

Now,

$$\begin{aligned} \int_{t_1}^{t_2} \frac{\partial T}{\partial \dot{q}_k} \delta \dot{q}_k dt &= \int_{t_1}^{t_2} \frac{\partial T}{\partial \dot{q}_k} \frac{d}{dt} (\delta q_k) dt = \frac{\partial T}{\partial \dot{q}_k} \underbrace{\delta q_k \Big|_{t_1}^{t_2}}_{=0} - \int_{t_1}^{t_2} \frac{d}{dt} \left(\frac{\partial T}{\partial \dot{q}_k} \right) \delta q_k dt \\ &= - \int_{t_1}^{t_2} \frac{d}{dt} \left(\frac{\partial T}{\partial \dot{q}_k} \right) \delta q_k dt \end{aligned} \quad (2.5.9)$$

Substituting (2.5.9) in (2.5.8) we have

$$\int_{t_1}^{t_2} \sum_{k=1}^n \left[- \frac{d}{dt} \left(\frac{\partial T}{\partial \dot{q}_k} \right) + \frac{\partial T}{\partial q_k} + Q_k \right] \delta q_k dt = 0 \quad (2.5.10)$$

Considering the arbitrariness of the virtual displacement δq_k , equation (2.5.10) will be satisfied for all values of δq_k provided

$$\boxed{\frac{d}{dt} \left(\frac{\partial T}{\partial \dot{q}_k} \right) - \frac{\partial T}{\partial q_k} = Q_k}, \quad k = 1, 2, \dots, n \quad (2.5.11)$$

Equation (2.5.11) is known as Lagrange's equation .

Considering both conservative force Q_{kc} and nonconservative force Q_{nkc} , the total generalized force Q_k can be written as

$$Q_k = Q_{kc} + Q_{nkc} \quad (2.5.12)$$

and recalling potential energy depends on coordinates alone, the work done by the conservative force W_c is equal to the negative of the potential energy V . Hence, one may write

$$\delta W_c = -\delta U = - \sum_{k=1}^n \frac{\partial V}{\partial q_k} \delta q_k = \sum_{k=1}^n Q_{kc} \delta q_k. \quad (2.5.13)$$

So the conservative generalized forces have the form

$$Q_{kc} = - \frac{\partial U}{\partial q_k}, \quad k=1, 2, \dots, n \quad (2.5.14)$$

Substituting Eq. (2.5.12) and Eq. (2.5.13) in Eq. (2.5.10) we have

$$\frac{d}{dt} \left(\frac{\partial T}{\partial \dot{q}_k} \right) - \frac{\partial T}{\partial q_k} + \frac{\partial U}{\partial q_k} = Q_{knc}, \quad k = 1, 2, \dots, n. \quad (2.5.15)$$

As the potential energy does not depend on velocity, using Lagrangian $L = T - U$, Eq. (2.5.15) can be rewritten as

$$\frac{d}{dt} \left(\frac{\partial L}{\partial \dot{q}_k} \right) - \left(\frac{\partial L}{\partial q_k} \right) = Q_{knc} \quad (2.5.16)$$

Using dissipation energy D , this equation further can be written as

$$\frac{d}{dt} \left(\frac{\partial L}{\partial \dot{q}_k} \right) - \left(\frac{\partial L}{\partial q_k} \right) + \left(\frac{\partial D}{\partial \dot{q}_k} \right) = Q_{knc} \quad (2.5.17)$$

Using both external forces and moments one may write the generalized force as

$$Q_k = \sum_i \bar{F}_i \cdot \frac{\partial \bar{r}_i}{\partial q_k} + \sum_i M_i \cdot \frac{\partial \omega_i}{\partial q_k}, \quad i = 1, 2, \dots, N, \quad k = 1, 2, \dots, n \quad (2.5.18)$$

M_i is the vector representation of the externally applied moments, ω_i is the system angular velocity about the axis along which the considered moment is applied.

- Lagrange equation can be used for any discrete system whose motion lends itself to a description in terms of generalized coordinates, which include rigid bodies.
- can be extended to distributed parameter system, but such system, they are not as versatile as the extended Hamilton's Principle

Let us take some examples to derive the equation of motion using Lagrange principle.

Example 2.5.1: Derive the equation of motion of a spring-mass-damper system with spring force given by $F_s = kx - \alpha x^3$ and damping force given by $F_d = c\dot{x} - \beta x^2 \dot{x}$. The external force acting on the system is given by $F = f_1 \sin \omega_1 t + f_2 \sin \omega_2 t$. Consider mass of the system as m and displacement from the static equilibrium point as x .

Solution: In this single degree of freedom system one can take x as the generalized coordinate. From the given expressions for different forces acting on the system, the expressions for kinetic energy T , potential energy V , dissipation energy D can be given by the following expressions.

$$T = \frac{1}{2} m \dot{x}^2, \quad (2.5.19)$$

$$V = \int F_s dx = \int (kx - \alpha x^3) dx = \frac{1}{2} kx^2 - \frac{1}{4} \alpha x^4$$

$$L = T - V = \frac{1}{2}m\dot{x}^2 - \left(\frac{1}{2}kx^2 - \frac{1}{4}\alpha x^4 \right) \quad (2.5.20)$$

$$D = \int F_d dx = \int (c\dot{x} - \beta x^2 \dot{x}) dx \quad (2.5.21)$$

$$Q_{knc} = F = f_1 \sin \omega_1 t + f_2 \sin \omega_2 t \quad (2.5.22)$$

Using Lagrange equation (2.5.17)

$$\frac{d}{dt} \left(\frac{\partial L}{\partial \dot{q}_k} \right) - \left(\frac{\partial L}{\partial q_k} \right) + \left(\frac{\partial D}{\partial \dot{q}} \right) = Q_{knc} \quad (2.5.23)$$

$$\frac{d}{dt} \left(\frac{\partial \left(\frac{1}{2}m\dot{x}^2 - \left(\frac{1}{2}kx^2 - \frac{1}{4}\alpha x^4 \right) \right)}{\partial \dot{x}} \right) - \left(\frac{\partial \left(\frac{1}{2}m\dot{x}^2 - \left(\frac{1}{2}kx^2 - \frac{1}{4}\alpha x^4 \right) \right)}{\partial x} \right) + F_d = F \quad (2.5.24)$$

$$\text{or, } \frac{d}{dt}(m\dot{x}) - (-F_s) + F_d = F \quad (2.5.25)$$

$$\text{or, } m\ddot{x} + kx - \alpha x^3 + (c\dot{x} - \beta x^2 \dot{x}) = f_1 \sin \omega_1 t + f_2 \sin \omega_2 t \quad (2.5.26)$$

Example 2.5.2

Use Lagrange Principle to derive equation of motion of the following system.

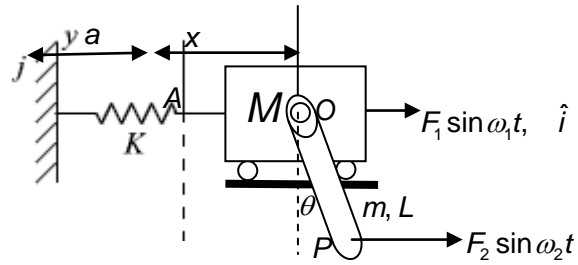

Figure 2.5.1: Vibration of a spring-mass system with a pivoted link

Solution:

Let A is the position of the mass M at time $t = 0$ when the link is in vertical position. Now it has come to position marked O after some time t . The motion can be completely described in terms of a physical coordinate system fixed at the fixed end. Also, one may use translation x of mass M and rotation θ of the link as the generalized coordinates. Here, $q_1 = x$ and $q_2 = \theta$. \hat{i} and \hat{j} are the unit vector along the horizontal and vertical direction as shown in the figure. To find the kinetic energy of the link, first we have to determine the velocity of the mass center of the link. The position vector of the mass center of the link is

$$\vec{r}_c = \left(a + x + \frac{L}{2} \sin \theta \right) \hat{i} - \frac{L}{2} \cos \theta \hat{j} \quad (2.5.27)$$

So the velocity

$$\vec{v}_c = \left(\dot{x} + \frac{L}{2} \cos \theta \dot{\theta} \right) \hat{i} + \frac{L}{2} \dot{\theta} \sin \theta \hat{j}. \quad (2.5.28)$$

Similarly velocity of mass M is $\frac{d\vec{r}_1}{dt} = \frac{d(a+x)\hat{i}}{dt} = \dot{x}\hat{i}$ (2.5.29)

Hence, kinetic energy of the system which is due to the kinetic energy of the mass M and the kinetic energy of link with mass m is

$$T = \frac{1}{2} M \dot{\vec{r}}_1 \cdot \dot{\vec{r}}_1 + \underbrace{\frac{1}{2} m \vec{v}_c \cdot \vec{v}_c}_{\text{Translational KE}} + \underbrace{\frac{1}{2} I_c \dot{\theta}^2}_{\text{Rotational KE}} \quad (2.5.30)$$

$$= \frac{1}{2} \left[(M+m) \dot{x}^2 + mL \dot{x} \dot{\theta} \cos \theta + \frac{1}{3} mL^2 \dot{\theta}^2 \right] \quad (2.5.31)$$

The potential energy of the system is due to the spring element and also due to the change in height of the link. Considering a hard spring with cubic nonlinearity, the potential energy V of the system can be given by the following equation.

$$V = \frac{1}{2} kx^2 + \frac{1}{4} \alpha x^4 + mg \frac{L}{2} (1 - \cos \theta) \quad (2.5.32)$$

As two forces are acting on the system, to find the generalized force first we have to find the position vector of the point where the forces are acting. For the force $F_1 \sin \omega_1 t$ the position vector from the fixed coordinate system is $\vec{r}_1 = (a+x)\hat{i}$. Similarly, for the second force which is acting on the pivoted link is $\vec{r}_2 = (a+x+L \sin \theta)\hat{i} + (-L \cos \theta)\hat{j}$. So the generalized forces can be obtained by using Eq. (2.5.18) as follows.

$$Q_{knc} = \sum_{i=1}^2 \vec{F}_i \cdot \frac{\partial \vec{r}_i}{\partial \mathbf{q}_k} \quad (2.5.33)$$

$$Q_{1nc} = \left[F_1 \sin \omega_1 t \hat{i} \cdot \frac{\partial (a+x)\hat{i}}{\partial x} + F_2 \sin \omega_2 t \hat{i} \cdot \frac{\partial ((a+x+L \sin \theta)\hat{i} + (-L \cos \theta)\hat{j})}{\partial x} \right] \quad (2.5.34)$$

$$= F_1 \sin \omega_1 t + F_2 \sin \omega_2 t$$

$$Q_{2nc} = \left[F_1 \sin \omega_1 t \hat{i} \cdot \underbrace{\frac{\partial (a+x)\hat{i}}{\partial \theta}}_{=0} + F_2 \sin \omega_2 t \hat{i} \cdot \frac{\partial ((a+x+L \sin \theta)\hat{i} + (-L \cos \theta)\hat{j})}{\partial \theta} \right] \quad (2.5.35)$$

$$= 0 + F_2 L \sin \omega_2 t \cos \theta = F_2 L \sin \omega_2 t \cos \theta$$

Now using Lagrange Principle

$$\frac{d}{dt} \left(\frac{\partial L}{\partial \dot{\mathbf{q}}_k} \right) - \frac{\partial L}{\partial \mathbf{q}_k} = Q_{knc} \quad (2.5.36)$$

Where

$$L = \frac{1}{2} \left[(M+m) \dot{x}^2 + mL \dot{\theta} \cos \theta + \frac{1}{3} mL^2 \dot{\theta}^2 \right] - \left[\frac{1}{2} kx^2 + \frac{1}{4} \alpha x^4 + mg \frac{L}{2} (1 - \cos \theta) \right] \quad (2.5.37)$$

For $k=1$

$$\frac{d}{dt} \left[(M+m) \dot{x} + mL \dot{\theta} \cos \theta \right] + kx + \alpha x^3 = F_1 \sin \omega_1 t + F_2 \sin \omega_2 t \quad (2.5.38)$$

For $k=2$

$$\frac{d}{dt} \left(mL \dot{x} \cos \theta + \frac{1}{3} mL^2 \dot{\theta} \right) + \frac{1}{2} mL \dot{x} \dot{\theta} \sin \theta + mg \frac{L}{2} \sin \theta = F_2 L \cos \theta \sin \omega_2 t \quad (2.5.39)$$

$$\text{or, } \frac{d}{dt} \left(mL \dot{x} \cos \theta + \frac{1}{3} mL^2 \dot{\theta} \right) + \frac{1}{2} mL (\dot{x} \dot{\theta} + g) \sin \theta = F_2 L \cos \theta \sin \omega_2 t \quad (2.5.40)$$

Example 2.5.2: Using Lagrange Principle to find the equation of motion of the system shown in Figure 2.5.2 . Spring K_1 is under pretension T for small amplitude of vertical Oscillation i.e., $|x/L| < 1$. Spring K_2 is a soft spring with cubic nonlinearity.

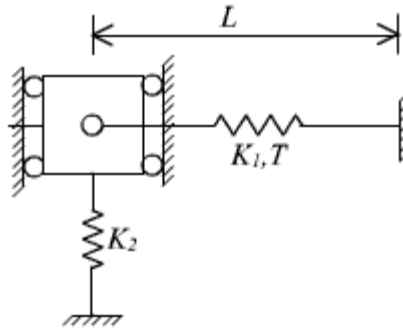

Figure 2.5.2: Vibration of a spring mass system with additional pre-tensioned horizontal spring.

Solution

As spring K_1 is under pretension T_0 which is produced by an initial extension of the spring by an amount δ_0 , one may write

$$T_0 = K_1 \delta_0 \quad (2.5.41)$$

The kinetic energy of the system is $T = \frac{1}{2} m \dot{x}^2$ (2.5.42)

The potential energy of the system is due to the potential energy of the nonlinear spring K_2 and due to the linear spring K_1 . Considering oscillations about the static equilibrium position, the potential energy can be obtained as follows.

$$V(x) = \frac{1}{2} K_1 (\delta_0 + \Delta l)^2 + \frac{1}{2} K_2 x^2 - \frac{1}{4} \epsilon K_2 x^4 \quad (2.5.43)$$

where ΔL is the change in length of the spring with stiffness K_1 due to the motion x of the mass. The coefficient of the cubic nonlinear term is assumed to be εK_2 . The negative sign is due to the soft spring assumption. For $|x/L| < 1$, from Fig. 2.5.3 one may write

$$\Delta L = \sqrt{L^2 + x^2} - L = L\sqrt{1 + \left(\frac{x}{L}\right)^2} - L \quad (2.5.44)$$

$$\approx L\left(1 + \frac{1}{2}\left(\frac{x}{L}\right)^2 - \frac{1}{8}\left(\frac{x}{L}\right)^4 + \frac{1}{16}\left(\frac{x}{L}\right)^6\right) - L = L\left(\frac{1}{2}\left(\frac{x}{L}\right)^2 - \frac{1}{8}\left(\frac{x}{L}\right)^4 + \frac{1}{16}\left(\frac{x}{L}\right)^6\right) \quad (2.5.45)$$

Hence the expression for potential energy is

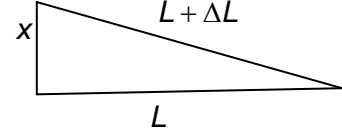

Figure 2.5.3

$$V(x) = \frac{1}{2}K_1\left(\delta_0 + L\left(\frac{1}{2}\left(\frac{x}{L}\right)^2 - \frac{1}{8}\left(\frac{x}{L}\right)^4 + \frac{1}{16}\left(\frac{x}{L}\right)^6\right)\right)^2 + \frac{1}{2}K_2x^2 - \frac{1}{4}\varepsilon K_2x^4 \quad (2.5.46)$$

Taking the generalized coordinate $q = x$, the Lagrangian of the system can be written as

$$L = T - V = \frac{1}{2}m\dot{x}^2 - \frac{1}{2}K_1\left(\delta_0 + L\left(\frac{1}{2}\left(\frac{x}{L}\right)^2 - \frac{1}{8}\left(\frac{x}{L}\right)^4 + \frac{1}{16}\left(\frac{x}{L}\right)^6\right)\right)^2 - \left(\frac{1}{2}K_2x^2 - \frac{1}{4}\varepsilon K_2x^4\right) \quad (2.5.47)$$

As no external force is acting on the system, the Lagrange Equation can be given by

$$\frac{d}{dt}\left(\frac{\partial L}{\partial \dot{x}}\right) - \frac{\partial L}{\partial x} = 0 \quad (2.5.48)$$

Neglecting the two higher order terms marked in blue in Eq. (2.5.47) and applying (2.5.48) one can get the following equation.

$$\frac{d}{dt}\left(\frac{1}{2}m\dot{x}\right) - \left\{-\frac{1}{2}K_1\left(\frac{x^3}{L^2} + 2\delta_0\frac{x}{L}\right) - \frac{1}{2}K_2x + \frac{1}{4}\varepsilon K_2 \cdot 4x^3\right\} = 0 \quad (2.5.49)$$

$$\text{Or, } m\ddot{x} - \left\{-\frac{1}{2}K_1\left(\frac{x^3}{L^2} + 2\delta_0\frac{x}{L}\right) - K_2x + \varepsilon K_2x^3\right\} = 0 \quad (2.5.50)$$

$$\text{Or, } m\ddot{x} + \left(\delta_0\frac{K_1}{L} + K_2\right)x + \left(\frac{K_1}{2L^2} - \varepsilon K_2\right)x^3 = 0 \quad (2.5.51)$$

$$\text{Or, } m\ddot{x} + \left(\frac{T_0}{K_1}\frac{K_1}{L} + K_2\right)x + \left(\frac{K_1}{2L^2} - \varepsilon K_2\right)x^3 = 0 \quad (2.5.52)$$

$$\text{Or, } m\ddot{x} + \left(\frac{T_0}{L} + K_2\right)x + \left(\frac{K_1}{2L^2} - \varepsilon K_2\right)x^3 = 0 \quad (2.5.53)$$

Exercise Problems

Problem 2.5.1 Use Lagrange equation to derive the equation of motion of the following system. Here, mass m_2 is subjected to a periodic force $f \sin \omega t$. Also, it is connected to a nonlinear spring in the right side.

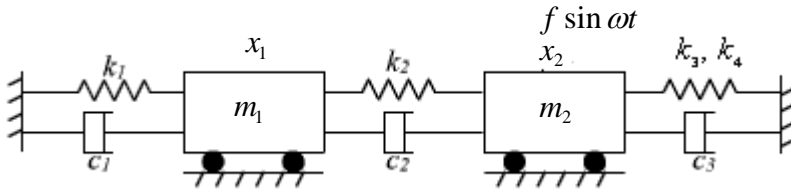

Figure 2.5.4: Multi degree of freedom system with nonlinear spring.

Hints:

Kinetic energy: $T = \frac{1}{2}(m_1 \dot{q}_1^2 + m_2 \dot{q}_2^2)$

Potential energy: $V = \frac{1}{2} \left[k_1 q_1^2 + k_2 (q_2 - q_1)^2 + k_3 q_2^2 + \frac{1}{2} k_4 q_2^4 \right]$

Rayleigh’s dissipation function can be written

$$D = \frac{1}{2} \left[c_1 \dot{q}_1^2 + c_2 (\dot{q}_2 - \dot{q}_1)^2 + c_3 \dot{q}_2^2 \right]$$

Problem 2.5.2: Derive the equation of motion of the following system using Lagrange principle. Consider the spring force as $f_s = k(x + 0.1x^3)$ and the damping force as $f_d = c(\dot{x} + 0.1x^2\dot{x} + 0.1\dot{x}^3)$.

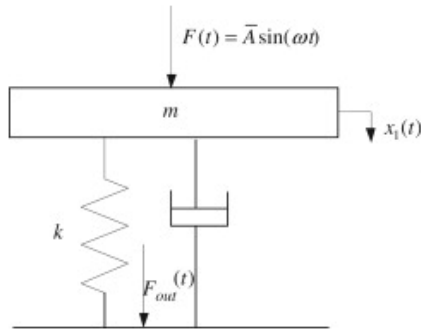

Figure 2.5.5: Vibration isolator with cubic nonlinear spring and damper

(Ref: Zhenlong Xiao, Xingjian Jing, Li Cheng, The transmissibility of vibration isolators with cubic nonlinear damping under both force and base excitations, Journal of Sound and Vibration, 332(5),1335-1354, 2013.)

Problem 2.5.3: Derive the equation of motion of a vibration isolator modeled by a linear spring and nonlinear damping. The nonlinear damping force can be given by $f_d = c(\dot{x} + 0.1x^2\dot{x} + 0.01\dot{x}^3)$

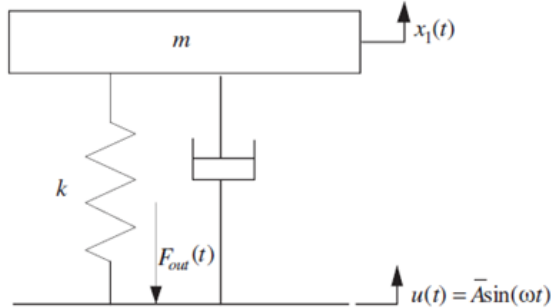

Figure 2.5.6: vibration isolators with cubic nonlinear damping under both force and base excitations

Answer: Governing equation of motion

$$m\ddot{x}_1 = k(u - x_1) + c(\dot{u} - \dot{x}_1) + 0.1c(u - x_1)^2(\dot{u} - \dot{x}_1) + 0.01c(\dot{u} - \dot{x}_1)^3$$

(Ref: Zhenlong Xiao, Xingjian Jing, Li Cheng, The transmissibility of vibration isolators with cubic nonlinear damping under both force and base excitations, Journal of Sound and Vibration, 332(5),1335-1354, 2013.)

Problem 2.5.4: Using Lagrange principle, derive the equation of motion of the shown system. The variation of spring force with displacement (x) of the mass M is given by $F_s = 5x + 0.5x^3$ kN, the damping force is given by $F_d = 0.2\dot{x}$ kN and the external applied force $F_t = 2 \sin 5t + 5 \sin 4t$ kN.

Take $M = 10$ kg, $L = 1$ m, $a = b = 0.25$ m. Write the equation of the system using book-keeping parameter. Consider the beam to be of negligible mass

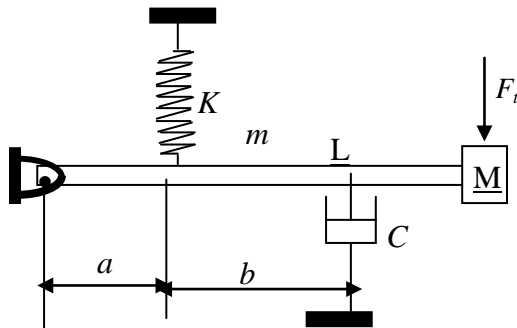

Solution

Figure 2.6.1 shows the system with a payload of mass m at the tip where a compressive force $P = P_0 + P_1 \cos \Omega_2 t$ is applied. Also this system is subjected to a harmonic base excitation $Y_b(t) = Z \cos \Omega_1 t$ at the roller supported left end. Here Z and Ω_1 are the amplitude and frequency of the base excitation, P_0, P_1 are the static and dynamic force amplitude, and Ω_2 is the frequency of the periodic force acting at the free end of the manipulator. The motion is considered to be in the vertical plane.

Using d'Alembert principle the equation of this system can be given by

$$\begin{aligned}
 EI \left(v_{ssss} + \frac{1}{2} v_s^2 v_{ssss} + 3v_s v_{ss} v_{sss} + v_{ss}^3 \right) + \rho A v_s \left(\int_0^s \dot{v}_\xi^2 + v_\xi \ddot{v}_\xi \right) + v_s v_{ss} \\
 \left(\int_s^L (\rho A \ddot{v} + c_d \dot{v}) d\eta + \rho A Y_b (L-s) + M(\ddot{v} + \ddot{Y}_b) - v_{ss} \left(\int_s^L \rho A \int_0^\xi \dot{v}_\zeta^2 + v_\zeta \ddot{v}_\zeta d\xi d\eta + M \left(\int_0^s \dot{v}_\zeta^2 + v_\zeta \ddot{v}_\zeta d\xi \right) \right) \right) \\
 \left(1 - \frac{1}{2} v_s^2 \right) (\rho A (\ddot{v} + \ddot{Y}_b) + c_d \dot{v}) + (P_0 + P_1 \cos \Omega_2 t) v_{ss} = 0
 \end{aligned} \quad (2.6.1)$$

Here, E, I, ρ, A, L and c_d are the Young modulus, moment of inertia, mass density, area of cross-section, length of the cantilever beam and damping factor of the system and ζ, η respectively, are used as integration variables. To determine the temporal equation of motion, one may discretize the governing equation of motion (2.6.1) by using following assumed mode expression.

$$v(s, t) = \sum_{i=1}^n r \psi_i(s) q_i(t). \quad (2.6.2)$$

Here, r is the scaling factor; $q_i(t)$ is the time modulation of the i^{th} mode and $\psi_i(s)$ is the eigenfunction of the cantilever beam with tip mass which is given by

$$\psi_i(s) = - \left(\frac{\sin \beta_i L + \sinh \beta_i L}{\cos \beta_i L + \cosh \beta_i L} \right) (\cos \beta_i s - \cosh \beta_i s) + (\sin \beta_i s - \sinh \beta_i s) \quad (2.6.3)$$

One may determine βL from the following equation.

$$1 + \cos \beta L \cosh \beta L + \bar{m} \beta L (\cos \beta L \sinh \beta L - \sin \beta L \cosh \beta L) = 0 \quad (2.6.4)$$

The following non-dimensional parameters are used in the further analysis.

$$\bar{x} = \frac{s}{L}, \tau = \omega t, \bar{\omega}_1 = \frac{\Omega_1}{\omega}, \bar{\omega}_2 = \frac{\Omega_2}{\omega}, \bar{\lambda} = \frac{r}{L}, \bar{m} = \frac{M}{\rho AL}, \chi = \frac{EI}{\rho AL^4}, \bar{r} = \frac{Z}{r}, \text{ and } \bar{Z} = \frac{Z}{L}.$$

Substituting the above mentioned nondimensional parameters and equation (2.6.2) into equation (2.6.1) one may obtain the residue equation R. Now taking $\psi_i(s)$ as the weight function and using the generalized Galerkin's method, one may write the following equation.

$$\int R\psi_i(s)dx = 0 \quad (2.6.5)$$

This equation can be written in the following form which is the non-dimensional temporal equation of motion of the system.

$$\begin{aligned} \ddot{q}_n + q + 2\varepsilon\zeta\dot{q}_n + \varepsilon \left(\sum_{i=1}^m \sum_{j=1}^m \sum_{k=1}^m (\alpha_{1nij} q_i q_j q_k + \alpha_{2nij} q_i q_j \ddot{q}_k + \alpha_{3nij} \dot{q}_i \dot{q}_j q_k) \right) + \\ \varepsilon \left(\sum_{i=1}^m \sum_{j=1}^m \alpha_{4nij} \bar{\omega}_1^2 \cos(\bar{\omega}_1 \tau) q_i q_j + \alpha_{5nij} \bar{\omega}_1^2 \cos(\bar{\omega}_2 \tau) + \alpha_{6nij} \cos(\bar{\omega}_2 \tau) q \right) = 0 \end{aligned} \quad (2.6.6)$$

[Derivation of only one/two terms are shown below. Taking only the first two terms in Eq. (2.6.1) and substituting (2.6.2) one may obtain the residue equation

$$EI \left(v_{SSSS} + \frac{1}{2} v_S^2 v_{SSSS} + \dots \right) \quad (2.6.7)$$

Substituting $v(s,t) = \sum_{i=1}^m r\psi_i(s)q_i(t)$ in the above equation

$$\begin{aligned} EI \left(\sum_{i=1}^n r\psi_i^{iv}(s)q_i(t) + \frac{1}{2} \sum_{i=1}^m (r\psi_i') \sum_{j=1}^m (r\psi_j') \sum_{k=1}^m (r\psi_k^{iv}) \right) \\ = EI \left(\sum_{i=1}^n r\psi_i^{iv}(s)q_i(t) + \frac{r^3}{2} \sum_{i=1}^m \sum_{j=1}^m \sum_{k=1}^m (\psi_i' \psi_j' \psi_k^{iv}) q_i q_j q_k \right) \end{aligned} \quad (2.6.8)$$

Taking weight function as ψ_n , multiplying ψ_n in the above equation and integrating over the domain one obtains

$$\begin{aligned} \int_0^l EI \left(\sum_{i=1}^m r\psi_i^{iv}(s)q_i(t) + \frac{r^3}{2} \sum_{i=1}^m \sum_{j=1}^m \sum_{k=1}^m (\psi_i' \psi_j' \psi_k^{iv}) q_i q_j q_k \right) \psi_n ds \\ = \int_0^l EI \left(\sum_{i=1}^m r\psi_i^{iv}(s)\psi_n q_i(t) + \frac{r^3}{2} \sum_{i=1}^m \sum_{j=1}^m \sum_{k=1}^m (\psi_i' \psi_j' \psi_k^{iv}) \psi_n q_i q_j q_k \right) ds \\ = rEIh_1^* \ddot{q}_n + \frac{r^3}{2} \sum_{i=1}^m \sum_{j=1}^m \sum_{k=1}^m \alpha_{ijk}^* q_i q_j q_k \end{aligned} \quad (2.6.9)$$

Where

$$\begin{aligned}
 h_1^* &= \int_0^l \left(\sum_{i=1}^m \psi_i^{iv} \psi_n \right) ds = \int_0^l \left(\underbrace{\psi_1^{iv} \psi_n + \psi_2^{iv} \psi_n + \psi_3^{iv} \psi_n + \dots}_{=0 \text{ due to orthogonality principle}} + \psi_n^{iv} \psi_n + \dots \right) ds \\
 &= \int_0^l \psi_n^{iv}(s) \psi_n(s) ds = \frac{1}{l^4} \int_0^l \psi_n^{iv} \psi_n l d\bar{x} = \frac{1}{l^3} h_1
 \end{aligned} \tag{2.6.10}$$

$$\begin{aligned}
 \alpha_{1ijk}^* &= \int_0^l EI \left(\sum_{i=1}^m \sum_{j=1}^m \sum_{k=1}^m \sum_{k=1}^m (\psi_i' \psi_j' \psi_k^{iv}) \psi_n \right) ds \\
 &= \frac{1}{l^5} \int_0^l EI \left(\sum_{i=1}^m \sum_{j=1}^m \sum_{k=1}^m \sum_{k=1}^m (\psi_i'(\bar{x}) \psi_j'(\bar{x}) \psi_k^{iv}(\bar{x})) \psi_n(\bar{x}) \right) d\bar{x} \\
 &= \frac{1}{l^5} \alpha_{1ijk}
 \end{aligned} \tag{2.6.11}$$

It may be noted that while h_1^* is in dimensional form h_1 is in the nondimensional form.

Similar procedures have to be followed to find all other terms.

Considering single mode discretization i.e. by substituting $m=1$, the above equation reduces to

$$\begin{aligned}
 \ddot{q} + q + 2 \varepsilon \zeta \dot{q} + \varepsilon \left(\alpha_1 q^3 + \alpha_2 q^2 \ddot{q} + \alpha_3 \dot{q}^2 q \right) + \\
 \varepsilon \left(\alpha_4 \bar{\omega}_1^2 \cos(\bar{\omega}_1 \tau) q^2 + \alpha_5 \bar{\omega}_1^2 \cos(\bar{\omega}_2 \tau) + \alpha_6 \cos(\bar{\omega}_2 \tau) q \right) = 0
 \end{aligned} \tag{2.6.12}$$

Eq. (2.6.12) is the required temporal equation of motion. The coefficients used in this equation are described below.

The natural frequency (ω_e) of the lateral vibration of an elastic beam

$$\omega_e = \sqrt{\frac{EI}{\rho A L^4} \left(\frac{h_{14}}{h_2} \right) + \frac{P_0}{\rho A L^2} \left(\frac{h_{21}}{h_2} \right)} = \sqrt{\chi \frac{h_{14}}{h_2} + \bar{P}_0 \left(\frac{h_{21}}{h_2} \right)} \tag{2.6.13}$$

$$\text{Damping ratio } (\zeta) = \frac{C_d}{2 \varepsilon \rho A \omega_e}, \tag{2.6.14}$$

Coefficient of the nonlinear geometric term q^3

$$= \alpha_1 = \frac{\chi \bar{\lambda}^2}{\varepsilon \omega_e^2} \left(\frac{h_{19}}{h_2} + \frac{h_{18}}{2h_2} + 3 \frac{h_{20}}{h_2} \right) \tag{2.6.15}$$

Coefficient of the nonlinear inertia term $q^2\ddot{q}$

$$= \alpha_2 = \frac{\bar{\lambda}^2}{\varepsilon} \left(\frac{h_3}{h_2} + \frac{h_4}{h_2} + \bar{m} \frac{h_5}{h_2} - \frac{h_6}{h_2} - \bar{m} \frac{h_7}{h_2} - \frac{h_8}{h_2} \right), \quad (2.6.16)$$

Coefficient of the nonlinear inertia term $\dot{q}^2 q$

$$= \alpha_3 = \frac{\bar{\lambda}^2}{\varepsilon} \left(\frac{h_{11}}{h_2} - \frac{h_{12}}{h_2} - \bar{m} \frac{h_{13}}{h_2} \right) \quad (2.6.17)$$

Coefficient of the term $q^2 \cos(\bar{\omega}_1 \tau)$

$$= \alpha_4 = \frac{\bar{Z}\bar{\lambda}}{\varepsilon} \left(\frac{h_{15}}{h_2} + \bar{m} \frac{h_{16}}{h_2} - \frac{h_{17}}{2h_2} \right) \quad (2.6.18)$$

Coefficient of the direct forced term $(\cos(\bar{\omega}_2 \tau))$, $\alpha_5 = \frac{\bar{r}}{\varepsilon} \left(\frac{h_1}{h_2} \right)$, (2.6.19)

Coefficient of the parametric excitation $(q \cos(\bar{\omega}_2 \tau))$, $\alpha_6 = \frac{P_1}{M \omega_e^2 L^2} \left(\frac{h_{21}}{h_2} \right) = \bar{P}_1 \left(\frac{h_{21}}{h_2} \right)$. (2.6.20)

Where

$$h_1 = \int_0^1 \psi_n^{iv} \psi_n ds, \quad h_2 = \int_0^1 [\psi(\bar{x})]^2 d\bar{x}, \quad h_3 = \int_0^1 \left[\frac{d\psi(\bar{x})}{d\bar{x}} \left(\int_0^x \left[\frac{d\psi(\bar{\xi})}{d\bar{\xi}} \right]^2 d\bar{\xi} \right) \psi(\bar{x}) \right] d\bar{x},$$

$$h_4 = \int_0^1 \left[\frac{d\psi(\bar{x})}{d\bar{x}} \frac{d^2\psi(\bar{x})}{d\bar{x}^2} \left[\int_x^1 \psi(\bar{\xi}) d\bar{\xi} \right] \psi(\bar{x}) \right] d\bar{x}, \quad h_5 = \int_0^1 \left[\frac{d\psi(\bar{x})}{d\bar{x}} \frac{d^2\psi_y(\bar{x})}{d\bar{x}^2} [\psi(\bar{x})]^2 \right] d\bar{x},$$

$$h_6 = \int_0^1 \left[\frac{d^2\psi(\bar{x})}{d\bar{x}^2} \left(\int_x^1 \int_0^\eta \left[\frac{d\psi(\bar{x})}{d\bar{\xi}} \right]^2 d\bar{\xi} d\bar{\eta} \right) \psi(\bar{x}) \right] d\bar{x}, \quad h_7 = \int_0^1 \left[\frac{d^2\psi(\bar{x})}{d\bar{x}^2} \left(\int_0^x \left[\frac{d\psi(\bar{\xi})}{d\bar{\xi}} \right]^2 d\bar{\xi} \right) \psi(\bar{x}) \right] d\bar{x},$$

$$h_8 = \int_0^1 \left[\frac{d\psi(\bar{x})}{d\bar{x}} \right]^2 [\psi(\bar{x})]^2 d\bar{x}, \quad h_9 = \int_0^1 \left[\frac{d\psi(\bar{x})}{d\bar{x}} \frac{d^2\psi(\bar{x})}{d\bar{x}^2} \left[\int_x^1 \psi(\bar{\xi}) d\bar{\xi} \right] \psi(\bar{x}) \right] d\bar{x},$$

$$h_{10} = \int_0^1 \left[\frac{d\psi(\bar{x})}{d\bar{x}} \right]^2 [\psi(\bar{x})]^2 d\bar{x}, \quad h_{11} = \int_0^1 \left[\frac{d\psi(\bar{x})}{d\bar{x}} \left(\int_0^x \left[\frac{d\psi(\bar{\xi})}{d\bar{\xi}} \right]^2 d\bar{\xi} \right) \psi(\bar{x}) \right] d\bar{x},$$

$$h_{12} = \int_0^1 \left[\frac{d^2\psi(\bar{x})}{d\bar{x}^2} \left(\int_x^1 \int_0^\eta \left[\frac{d\psi(\bar{\xi})}{d\bar{\xi}} \right]^2 d\bar{\xi} d\bar{\eta} \right) \psi(\bar{x}) \right] d\bar{x}, \quad h_{13} = \int_0^1 \left[\frac{d^2\psi(\bar{x})}{d\bar{x}^2} \left(\int_0^x \left[\frac{d\psi(\bar{\xi})}{d\bar{\xi}} \right]^2 d\bar{\xi} \right) \psi(\bar{x}) \right] d\bar{x},$$

$$h_{14} = \int_0^1 \left[\frac{d^4 \psi(\bar{x})}{d\bar{x}^4} \psi(\bar{x}) d\bar{x} \right], \quad h_{15} = \int_0^1 \left[(1 - \bar{x}) \frac{d\psi(\bar{x})}{d\bar{x}} \frac{d^2 \psi(\bar{x})}{d\bar{x}^2} \psi(\bar{x}) d\bar{x} \right],$$

$$h_{16} = \int_0^1 \left[\frac{d\psi(\bar{x})}{d\bar{x}} \frac{d^2 \psi(\bar{x})}{d\bar{x}^2} \psi(\bar{x}) d\bar{x} \right], \quad h_{17} = \int_0^1 \left[\frac{d\psi(\bar{x})}{d\bar{x}} \right]^2 \psi(\bar{x}) d\bar{x}, \quad h_{18} = \int_0^1 \left[\left(\frac{d\psi(\bar{x})}{d\bar{x}} \right)^2 \frac{d^4 \psi(\bar{x})}{d\bar{x}^4} \psi(\bar{x}) d\bar{x} \right],$$

$$h_{19} = \int_0^1 \left[\frac{d^2 \psi(\bar{x})}{d\bar{x}^2} \psi(\bar{x}) d\bar{x} \right], \quad h_{20} = \int_0^1 \left[\frac{d\psi(\bar{x})}{d\bar{x}} \frac{d^2 \psi(\bar{x})}{d\bar{x}^2} \frac{d^3 \psi(\bar{x})}{d\bar{x}^3} \psi(\bar{x}) d\bar{x} \right],$$

$$\text{and } h_{21} = \int_0^1 \left[\frac{d^2 \psi(\bar{x})}{d\bar{x}^2} \psi(\bar{x}) d\bar{x} \right].$$

One may find that the non-dimensional temporal equation (2.6.12) has a linear forced term $(\alpha_5 \bar{\omega}_1^2 \cos \bar{\omega}_1 \tau)$, a linear parametric term $(\alpha_6 \cos(\bar{\omega}_2 \tau) q)$ and a nonlinear parametric excitation term $\left((\alpha_4 \bar{\omega}_1^2 \cos \bar{\omega}_1 \tau) q^2 \right)$ along with cubic geometric $(a_1 q^3)$ and inertial $(\alpha_2 q^2 \ddot{q} + \alpha_3 \dot{q}^2 q)$ nonlinear terms. Here the system is subjected to a two-frequency excitation. One may note that the temporal equation of motion contains many nonlinear terms and it is very difficult to find the exact solution. Hence one may go for approximate solution by solving equation (2.6.12) using perturbation method.

Exercise Problems:

Problem 2.6.1:

Derive the temporal equation of motion of a micro-beam system whose spatio-temporal equation is given below [1]

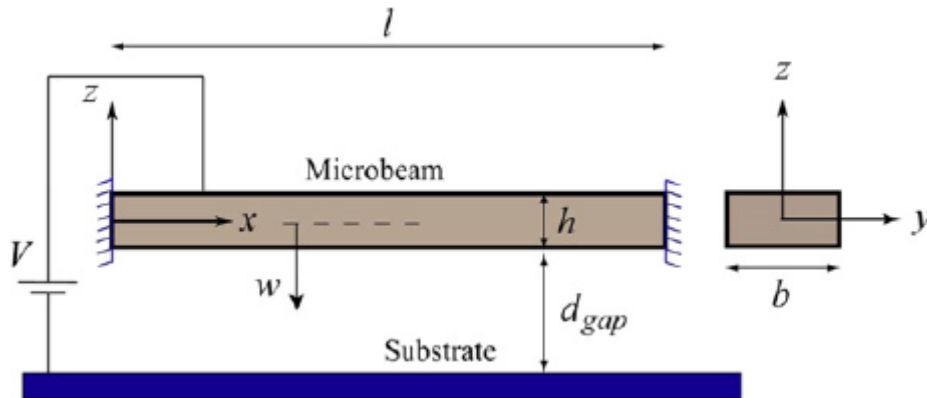

Fig 2.6.2: Schematic diagram of a clamped-clamped micro-beam.

$$\rho b h w_{tt} + EI w_{xxxx} - \left(N_i + \frac{Ebh}{2l} \int_0^l w_x^2 dx \right) w_{xx} - \frac{b\varepsilon V^2}{2} \left(\frac{1}{d_{gap}^2} + \frac{2w(x,t)}{d_{gap}^3} + \frac{3w(x,t)^2}{d_{gap}^4} + \frac{4w(x,t)^3}{d_{gap}^5} + \dots \right) - \frac{\varepsilon\beta V^2}{2} \left(\frac{1}{d_{gap}} + \frac{w(x,t)}{d_{gap}^2} + \frac{w(x,t)^2}{d_{gap}^3} + \frac{w(x,t)^3}{d_{gap}^4} + \dots \right) = 0$$

Answer:

$$\frac{d^2 \bar{q}}{d\tau^2} + \beta_1 \bar{q}(\tau) + 1 \left[\beta_2 (\bar{q}(\tau))^2 + \beta_3 (\bar{q}(\tau))^3 + \beta_4 (\bar{q}(\tau))^4 + \beta_5 \right] = 0$$

Problem 2.6.2:

The equation of motion of a base excited cantilever beam with arbitrary mass position can be given by the following equation. Derive the temporal equation of motion using single mode approximation.

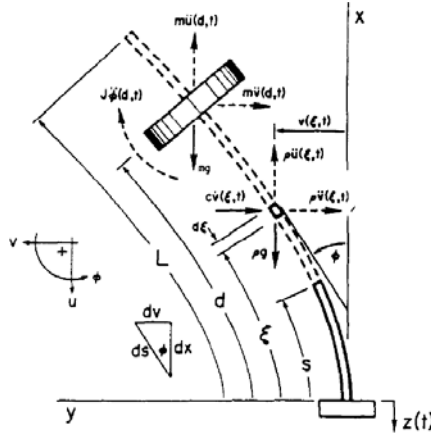

Fig 2.6.3: Schematic diagram of a base excited cantilever beam with arbitrary mass position.

$$EI \left(v_{ssss} + \frac{1}{2} v_s^2 v_{ssss} + 3v_s v_{ss} v_{sss} + v_{ss}^3 \right) + (1 - 0.5v_s^2) \{ (\rho + m\delta(s-d)) \ddot{v} + c\dot{v} \} + v_s v_{ss} \int_s^L \{ (\rho + m\delta(s-d)) \ddot{v} + c\dot{v} \} d\zeta - \frac{\partial}{\partial s} [J\delta(s-d)(v_s)_{tt}] - \frac{\partial}{\partial s} (Nv_s) = 0$$

Where

$$N = \frac{1}{2} \rho \int_s^L \left[\int_0^\zeta (v_s^2)_{tt} d\eta \right] d\zeta - \frac{1}{2} m \int_s^L \delta(\zeta - d) \left[\int_0^\zeta (v_s^2)_{tt} d\eta \right] d\zeta + m(\ddot{z} - g) \int_s^L \delta(\zeta - d) d\zeta + \rho L \left(1 - \frac{s}{L} \right) (\ddot{z} - g)$$

Answer:

$$\ddot{q} + 2\varepsilon\zeta\dot{q} + \omega^2 (1 - \varepsilon f \cos \Omega t) q + \varepsilon (\alpha_1 q^3 + \alpha_2 q^2 \ddot{q} + \alpha_3 \dot{q}^2 q) = 0$$

Problem 2.6.3:

For the same system given in problem 2.6.2, carryout two mode approximation to derive the temporal equation of motion. [3]

Answer:

$$\ddot{q}_n + 2\varepsilon\zeta\dot{q}_n + \omega_n^2 q_n - \varepsilon \sum_{m=1}^2 f_{nm} q_m \cos \Omega t + \varepsilon \sum_{k=1}^2 \sum_{l=1}^2 \sum_{m=1}^2 \left(\alpha_{klm}^n q_k q_l q_m + \beta_{klm}^n q_k \dot{q}_l \dot{q}_m + \gamma_{klm}^n q_k q_l \ddot{q}_m \right) = 0$$

where $n = 1, 2$.

References

1. H. M. Sedighi, K. H. Shirazi, Vibration of micro-beam actuated by an electric field via Parameter Expansion Method, Acta Astronautica, 85, 19-24, 2013.
2. L.D. Zavodney, A.H. Nayfeh, the nonlinear response of a slender beam carrying a lumped mass to a principal parametric excitation : theory and experiment, International Journal of Nonlinear Mechanics, 24,105-125, 1989.
3. R.C. Kar and S.K. Dwivedy, Nonlinear dynamics of a slender beam carrying a lumped mass with principal parametric and internal resonances, International Journal of Nonlinear Mechanics, 34, 515-529, 1999.

Lecture M2 L07

Ordering and scaling technique in nonlinear equations

In the previous lectures we learned about the derivation of equation of motion of both discrete and distributed mass system. In the later case the equation has been reduced to its temporal form. In these equations the coefficients of different terms used in the differential equations may not be of the same order and hence sometimes some terms get neglected in comparison to other terms. But for accurate solution one should take as many term as possible and hence it is required to know the ordering and scaling techniques. So in this lecture following points will be discussed with the help of examples.

- Ordering techniques,
- scaling parameters,
- Book-keeping parameter.
- Commonly used nonlinear equations: Duffing equation, Van der Pol's oscillator, Mathieu's and Hill's equations

Let us consider the equation we have derived for the simple pendulum. It can be written as

$$\ddot{\theta} + \frac{g}{l} \sin \theta = 0 \quad (2.7.1)$$

Keeping up to quintic nonlinearity Eq. (2.7.1) can be written as

$$\ddot{\theta} + \frac{g}{l} \theta - \frac{g}{l} \frac{\theta^3}{6} + \frac{g}{l} \frac{\theta^5}{120} = 0 \quad (2.7.2)$$

Taking the length of the pendulum 1 m and acceleration due to gravity as 10 m/s^2 , the equation of motion can be written as

$$\ddot{\theta} + 10\theta - 1.6667\theta^3 + 0.0083\theta^5 = 0 \quad (2.7.3)$$

In Eq. (2.7.3), the coefficient of the linear term θ is 10, the coefficient of cubic nonlinear term is -1.667 and the coefficient of quintic term is 0.008. As the coefficients of quintic and cubic terms are very very less than the linear term, one can neglect these terms to obtain the approximate solution. But to obtain the accurate solution one should consider these terms. One can use scaling parameter and book-keeping parameters to make the coefficient of nonlinear and linear terms of the same order so that the effect of these nonlinear terms can be taken into account.

To use scaling factor, let us take $\theta = py$ and substitute this in Eq. (2.7.3). Now the resulting equation can be written as

$$p\ddot{y} + 10py - 1.6667p^3y^3 + 0.0083p^5y^5 = 0 \quad (2.7.4)$$

$$\text{Or, } \ddot{y} + 10y - 1.6667p^2y^3 + 0.0083p^4y^5 = 0 \quad (2.7.5)$$

Now by taking different values of p , the coefficient of the nonlinear terms can be changed significantly without changing the coefficient of the linear part. For example, taking $p = 10$, the above equation becomes

$$\ddot{y} + 10y - 166.67y^3 + 83y^5 = 0 \quad (2.7.6)$$

Taking $p = 5$, Eq. (2.7.5) can be written as

$$\ddot{y} + 10y - 41.667y^3 + 5.1875y^5 = 0 \quad (2.7.7)$$

While in Eq. (2.7.6) the coefficient of linear and non-linear terms have large differences, in Eq. (2.7.7), these coefficients are closer to each other. Hence by suitably choosing the value of p , it is possible to bring the coefficient of the linear and nonlinear terms to the same order and in that case, instead of neglecting the higher order terms, one can consider these terms and solve the equation to obtain more accurate response.

Considering Eq. (2.7.3), as the coefficients of the cubic and quintic order terms are very very small in comparison to the coefficient of the linear term, one can use a book-keeping parameter ε ($\varepsilon \ll 1$) to order the coefficients. In this case one may write Eq. (2.7.3) as

$$\ddot{\theta} + 10\theta - \varepsilon \left(\frac{1.6667}{\varepsilon} \right) \theta^3 + \varepsilon^3 \left(\frac{0.0083}{\varepsilon^3} \right) \theta^5 = 0 \quad (2.7.8)$$

Taking $\varepsilon = 0.1$, Eq. (2.7.8) can be rewritten as

$$\ddot{\theta} + 10\theta - \varepsilon 16.667\theta^3 + \varepsilon^3 8.3\theta^5 = 0 \quad (2.7.9)$$

In Eq. (2.7.9) now the numerical part of the coefficients (16.667 and 8.3) are approximately same orders as that of the linear terms (i.e. 10). So in this way one can use the book-keeping parameter to order the nonlinear terms in a given nonlinear differential equation of motion.

Commonly used nonlinear equation of motion

Duffing equation (Free vibration with quadratic nonlinear term)

$$\frac{d^2u}{dt^2} + \omega_0^2u + \varepsilon\alpha u^2 = 0 \quad (2.7.10)$$

Duffing equation (Free vibration with cubic nonlinear term)

$$\frac{d^2u}{dt^2} + \omega_0^2u + \varepsilon\alpha u^3 = 0 \quad (2.7.11)$$

Duffing equation (Free vibration with both quadratic and cubic nonlinear terms)

$$\frac{d^2u}{dt^2} + \omega_0^2 u + \varepsilon \alpha_1 u^2 + \varepsilon \alpha_2 u^3 = 0 \quad (2.7.12)$$

Duffing equation with damping and weak forcing terms

$$\ddot{x} + \omega_n^2 x + 2\varepsilon \zeta \omega_n \dot{x} + \varepsilon \alpha x^3 = \varepsilon f \cos \Omega t \quad (2.7.13)$$

Duffing equation with damping and strong forcing terms

$$\ddot{x} + \omega_n^2 x + 2\varepsilon \zeta \omega_n \dot{x} + \varepsilon \alpha x^3 = f \cos \Omega t \quad (2.7.14)$$

Duffing equation with multi-frequency excitation

$$\ddot{x} + \omega_n^2 x + 2\varepsilon \zeta \omega_n \dot{x} + \varepsilon \alpha x^3 = f_1 \cos \Omega_1 t + f_2 \cos \Omega_2 t + f_3 \cos \Omega_3 t + \dots \quad (2.7.15)$$

Rayleigh's equation

$$\frac{d^3u}{dt^3} + \omega_0^2 u - \varepsilon (\dot{u} - \dot{u}^3) = 0 \quad (2.7.16)$$

Substituting $v = \sqrt{3}\dot{u}$ in Eq. (2.7.16) and differentiating the resulting equation with respect to time one will obtain the van der Pol's equation as follows

$$\frac{d^2v}{dt^2} + \omega_0^2 v = \varepsilon (1 - v^2) \frac{dv}{dt} \quad (2.7.17)$$

Hill's equation

$$\ddot{x} + p(t)x = 0 \quad (2.7.18)$$

Mathieu's equation

$$\ddot{x} + (\omega_n^2 + 2\varepsilon f \cos \Omega t)x = 0 \quad (2.7.19)$$

Mathieu's equation with cubic nonlinearities and forcing terms

$$\ddot{x} + (\omega_n^2 + 2\varepsilon f_1 \cos \Omega_1 t)x + \varepsilon \alpha x^3 = \varepsilon f_2 \cos \Omega_2 t \quad (2.7.20)$$

Lorentz equation

$$\begin{aligned} \dot{x} &= \sigma(y - x) \\ \dot{y} &= rx - y - xz \\ \dot{z} &= xy - bz \end{aligned} \quad (2.7.21)$$

Here $\sigma, r, b > 0$ are parameters

Generic equation for one dimensional pitchfork bifurcation

$$\dot{x} = \mu - x^2$$

Generic equation for saddle-node bifurcation

$$\dot{x} = \mu x + \alpha x^3$$

Generic equation for transcritical bifurcation

$$\dot{x} = \mu x - x^2$$

Equation for Hopf bifurcation

$$\dot{r} = \mu r + \alpha r^3$$

$$\dot{\theta} = \omega + \beta r^2$$

Exercise problems

Problem 2.7.1:

Use scaling parameter to order the following equation.

- (i) $3\ddot{x} + 30x - 0.1x^2 + 0.05x^3 = 0$
- (ii) $\ddot{x} + 20x - 0.5x^2 + 0.05x^3 = 10 \sin 5t$
- (iii) $\ddot{x} + 50x - 0.5x^2 + 0.3x^3 = 0.1 \sin 2t$
- (iv) $\ddot{x} + 50x - (0.1 \sin 2t)x = 0$
- (v) $\ddot{x} + 50x - 0.25x^2 - (0.1 \sin 2t)x = 0$
- (vi) $\ddot{x} + 50x + 0.25x^3 + (0.1 \sin 2t)x = 0$

Problem 2.7.2:

Figure 2.7.1 shows a two-stage nonlinear vibration isolation system whose equation of motion is given below. Using book-keeping parameter, write the equation of motion by taking different values of $m, k_1, k_3, k_{v1}, k_{h1}, c_1, \omega$.

$$m\ddot{x} + c_1\dot{x} + k_1x + k_3x^3 = F_e \cos(\omega t)$$

where $F_e = k_{v1}x + 2k_{h1} \left(1 - \frac{l_0}{\sqrt{x^2 + l^2}} \right) x$

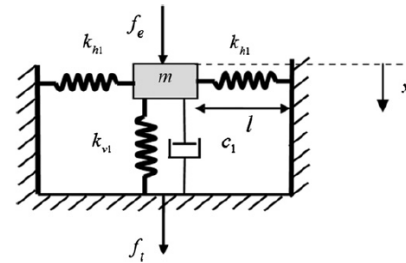

Fig. 2.7.1: Two-stage nonlinear vibration isolation system [1]

Problem 2.7.3:

Write the equation of motion for system with (a) fractional order, (b) time delay, (c) piecewise nonlinearity, (d) random excitation, (e) gyroscopic effect, (f) contact, (g) backlash (h) friction and wear.

Problem 2.7.4:

Study the nonlinear systems given in the references [2-13]. Taking numerical values and using ordering and scaling parameters write the equation of motion. Use Matlab to solve the temporal equation of motion in each case.

Reference for further reading

1. Z. Lu, M. J. Brennan, T. Yang, X. Li, and Z. Liu, An investigation of a two-stage nonlinear vibration isolation system, *Journal of Sound and Vibration*, 332 (6), 1456-1464, 2013.
2. A. Carrella, M. J. Brennan, T. P. Waters, and K. Shin, Introducing stiffness nonlinearity using magnets to improve vibration isolation, *Journal of Sound and Vibration*, 315 (3), 712–720, 2008.
3. R.A. Ibrahim, Recent advances in nonlinear passive vibration isolators, *Journal of Sound and Vibration*, 314(3–5), 371–452, 2008. (Review paper)
4. H. M. Sedighi, K. H. Shirazi, Vibrations of micro-beams actuated by an electric field via Parameter Expansion Method, *Acta Astronautica*, 85, 19-24, 2013.
5. A. D. S. Barr and D. C. McWhannel, Parametric instability in structures under support motion, *Journal of Sound and Vibration* 14, 491—509,1971.
6. V. V. Bolotin, *The Dynamic Stability of Elastic Systems*, Holden-Day, Inc,1964.
7. M.P. Cartmell, The equations of motion for a parametrically excited cantilever beam, *Journal of Sound and Vibration* 143, 395-405,1990.
8. G. Chakraborty and A.K. Mallik, Parametrically excited non-linear traveling beams with and without external forcing, *Nonlinear Dynamics* 17, 301–324, 1998.
9. G. Chakraborty, A.K. Mallik, and H. Hatwal, Non-linear vibration of a traveling beam. *International Journal of Non-Linear Mechanics* 34, 655–670, 1999.
10. O. Cuvalci and A. Ertas, Pendulum as vibration absorber for flexible structures: experiments and theory, *Journal of Vibration and Acoustics: Trans. of ASME*, 118, 558-566, 1996.
11. S.K. Dwivedy and R.C. Kar, Nonlinear response of a parametrically excited system using higher order method of multiple scales, *Nonlinear Dynamics* 20, 115–130, 1999.
12. S.A. Emam and A.H. Nayfeh, Nonlinear response of buckled beams to subharmonic-resonance excitations, *Nonlinear Dynamics* 35,105–122, 2004.
13. H.P. Lee, Stability of a cantilever beam with tip mass subjected to axial sinusoidal excitations, *Journal of Sound and Vibration* 183, 91–98,1995.
14. S.N. Mahmoodi, S.E. Khadem, and M. Kokabi, Non-linear free vibrations of Kelvin–Voigt visco-elastic beams, *International Journal of Mechanical Science* 49, 722–732, 2007.