

Example Problem

An Industrial building of plan 15m×30m is to be constructed as shown in Fig.E1. Using plastic analysis, analyse and design the single span portal frame with gabled roof. The frame has a span of 15 m, the column height is 6m and the rafter rise is 3 m and the frames are spaced at 5 m centre-to-centre. Purlins are provided over the frames at 2.7 m c/c and support AC sheets. The dead load of the roof system including sheets, purlins and fixtures is 0.4 kN/m² and the live load is 0.52 kN/m². The portal frames support a gantry girder at 3.25 m height, over which an electric overhead travelling (EOT) crane is to be operated. The crane capacity is to be 300 kN and the crane girder weighs 300 kN while the crab (trolley) weight is 60 kN.

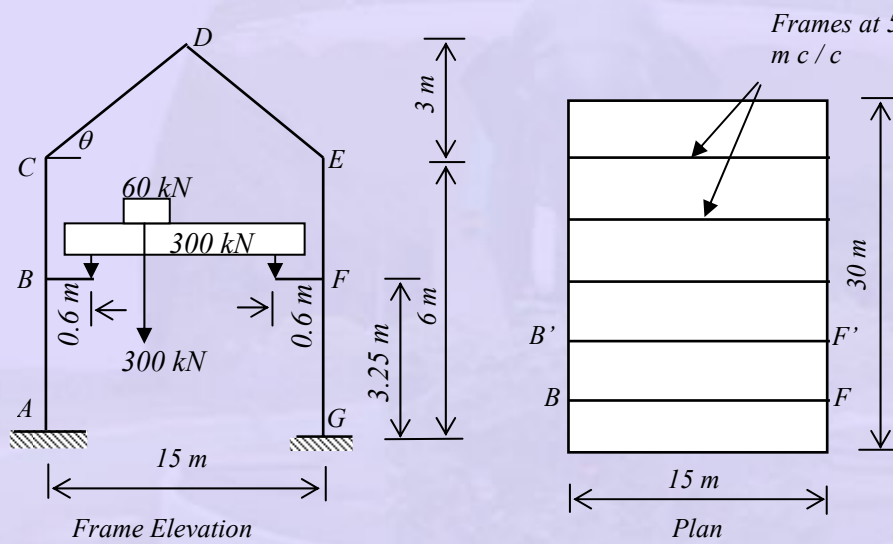

Fig. E1 Details of an Industrial Building

1.0 Load Calculations

1.1 Dead Load of roof given as 0.4 kN/m²

$$\text{Dead load/m run on rafter} = 0.4 * 5 \approx 2.0 \text{ kN/m}$$

1.2 Live Load given as 0.52 kN/m²

$$\text{Live load/m run on rafter} = 0.52 * 5 \approx 2.6 \text{ kN/m}$$

1.3 Crane Load

The extreme position of crane hook is assumed as 1 m from the centre line of rail. The span of crane is approximately taken as 13.8 m. And the wheel base along the gantry girder has been taken as 3.8 m

1.3.1 Vertical load on gantry

The weight of the crane is shared by two portal frames. At the extreme position of crab, the reaction on wheel due to the lifted weight and the crab can be obtained by taking moments about the centreline of wheels (point B).

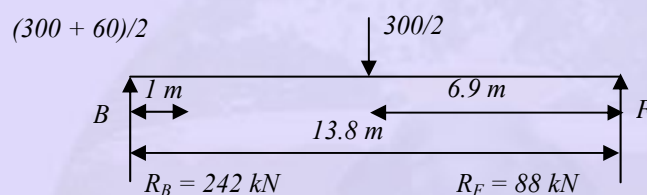

To get maximum wheel load on a frame from gantry girder BB', taking the gantry girder as simply supported.

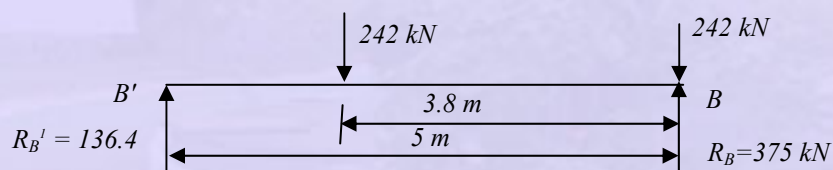

Centre to centre distance between frames is 5 m c/c.

Assuming impact factor of 25%

Maximum wheel Load @ B = $1.25 (242 (1 + (5-3.8)/5))$

$$= 375 \text{ kN.}$$

Minimum wheel Load @ B = $(88 / 242) * 375$

$$= 136.4 \text{ kN}$$

1.3.2 Transverse Load (Surge):

Lateral load per wheel = $5\% (300 + 60)/2 = 9 \text{ kN}$

(i.e. Lateral load is assumed as 5% of the lifted load and the weight of the crab acting on each rail).

Lateral load on each column = $\frac{9}{242} * 375 = 13.9 \text{ kN}$

(By proportion)

1.4 Wind Load

Design wind speed, $V_z = k_1 k_2 k_3 V_b$

From Table 1; IS: 875 (part 3) – 1987

$k_1 = 1.0$ (risk coefficient assuming 50 years of design life)

From Table 2; IS: 875 (part 3) – 1987

$k_2 = 0.8$ (assuming terrain category 4)

$k_3 = 1.0$ (topography factor)

Assuming the building is situated in Chennai, the basic wind speed is 50 m/sec

Design wind speed, $V_z = k_1 k_2 k_3 V_b$

$$V_z = 1 * 0.8 * 1 * 50$$

$$V_z = 40 \text{ m/sec}$$

Design wind pressure, $P_d = 0.6 * V_z^2$

$$= 0.6 * (40)^2$$

$$= 0.96 \text{ kN/m}^2$$

1.4.1. Wind Load on individual surfaces

The wind load, W_L acting normal to the individual surfaces is given by

$$W_L = (C_{pe} - C_{pi}) A P_d$$

(a) Internal pressure coefficient

Assuming buildings with low degree of permeability

$$C_{pi} = \pm 0.2$$

(b) External pressure coefficient

External pressure coefficient for walls and roofs are tabulated in Table 1 (a) and Table 1(b)

1.4.2 Calculation of total wind load

(a) For walls

$$h/w = 6/15 = 0.4$$

$$L/w = 30/15 = 2.0$$

Exposed area of wall per frame @ 5 m

$$c/c \text{ is } A = 5 * 6 = 30 \text{ m}^2$$

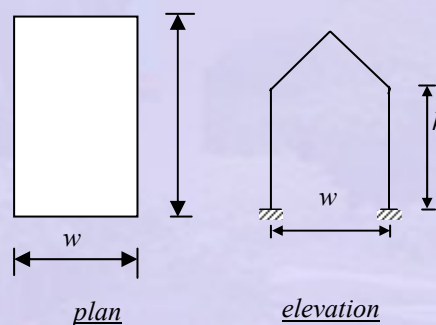

Wind load on wall / frame, $A p_d = 30 * 0.96 = 28.8 \text{ kN}$

Table 1 (a): Total wind load for wall

Wind Angle θ	C_{pe}		C_{pi}	$C_{pe} - C_{pi}$		Total wind(kN) $(C_{pe} - C_{pi}) A p_d$	
	Wind-ward	Lee-ward		Wind-ward	Lee-ward	Wind-ward	Lee-ward
0°	0.7	-0.25	0.2	0.5	-0.45	14.4	-12.9
			-0.2	0.9	-0.05	25.9	-1.4
90°	-0.5	-0.5	0.2	-0.7	-0.7	-20.2	-20.2
			-0.2	-0.3	-0.3	-8.6	-8.6

(b) For roofs

Exposed area of each slope of roof, per frame (5m length) is

$$A = 5 * \sqrt{(3.0)^2 + (7.5)^2} = 40.4 \text{ m}^2$$

For roof, $A_{p_d} = 38.7 \text{ kN}$

Table 1 (b): Total wind load for roof

Wind angle	Pressure Coefficient			$C_{pe} - C_{pi}$		Total Wind Load(kN) ($C_{pe} - C_{pi}$) A_{p_d}	
	C_{pe}	C_{pe}	C_{pi}	Wind ward	Lee ward	Wind ward	Lee ward
	Wind	Lee				Int.	Int.
0°	-0.328	-0.4	0.2	-0.528	-0.6	-20.4	-23.2
	-0.328	-0.4	-0.2	-0.128	-0.2	-4.8	-7.8
90°	-0.7	-0.7	0.2	-0.9	-0.9	-34.8	-34.8
	-0.7	-0.7	-0.2	-0.5	-0.5	-19.4	-19.4

2.1 Dead Load

Replacing the distributed dead load of 2kN/m on rafter by equivalent concentrated loads at two intermediate points corresponding to purlin locations on each rafter,

$$W_D = \frac{2.0 * 15}{6} = 5 \text{ kN}$$

2.2 Superimposed Load

Superimposed Load = 2.57 kN/m

$$\text{Concentrated load, } W_L = \frac{2.57 * 15}{6} = 6.4 \text{ kN}$$

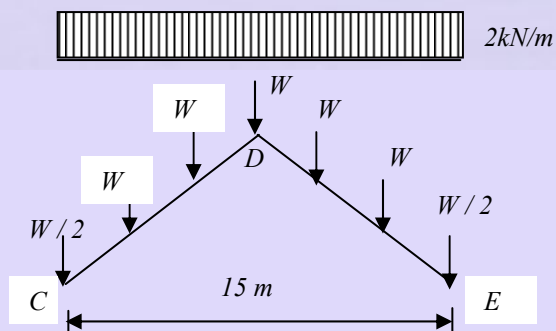

2.3 Crane Load

Maximum Vertical Load on columns = 375 kN (acting at an eccentricity of 600 mm from column centreline)

Moment on column = $375 * 0.6 = 225$ kNm.

Minimum Vertical Load on Column = 136.4 kN (acting at an eccentricity of 600 mm)

Maximum moment = $136.4 * 0.6 = 82$ kNm

3.0 Partial Safety Factors

3.1 Load Factors

For dead load, $\gamma_f = 1.5$

For leading live load, $\gamma_f = 1.5$

For accompanying live load, $\gamma_f = 1.05$

3.2 Material Safety factor

$$\gamma_m = 1.10$$

4.0 Analysis

In this example, the following load combinations is considered, as it is found to be critical. Similar steps can be followed for plastic analysis under other load combinations.

(i) $1.5D.L + 1.5 C .L + 1.05 W.L$

4.1. 1.5 D.L + 1.5 C.L+ 1.05 W.L

4.1.1 Dead Load and Wind Load along the ridge (wind angle = 0 °)

(a) Vertical Load

w @ intermediate points on windward side

$$w = 1.5 * 5.0 - 1.05 * (4.8/3) \cos 21.8$$

$$= 6 \text{ kN.}$$

$$\frac{w}{2} @ \text{ eaves} = \frac{6}{2} = 3.0 \text{ kN}$$

w @ intermediate points on leeward side

$$w = 1.5 * 5.0 - 1.05 * 7.8/3 \cos 21.8$$

$$= 5.0 \text{ kN}$$

$$\frac{w}{2} @ \text{ eaves} = \frac{5.0}{2} = 2.5 \text{ kN}$$

Total vertical load @ the ridge = 3.0 + 2.5 = 5.5 kN

b) Horizontal Load

H @ intermediate points on windward side

$$H = 1.05 * 4.8/3 \sin 21.8$$

$$= 0.62 \text{ kN}$$

$$\begin{aligned} H/2 @ \text{ eaves points} &= 0.62/2 \\ &= 0.31 \text{ kN} \end{aligned}$$

H @ intermediate purlin points on leeward side

$$\begin{aligned} &= 1.05 * 7.8 /3 \sin 21.8 \\ &= 1 \text{ kN} \end{aligned}$$

$$H/2 @ \text{ eaves} = 0.5 \text{ kN}$$

Total horizontal load @ the ridge = 0.5 - 0.31 = 0.19 kN

Table 3: Loads acting on rafter points

Intermediate Points	Vertical Load (kN)		Horizontal Load (kN)	
	Windward	Leeward	Windward	Leeward
Intermediate Points	5.2	4.2	0.62	1.0
Eaves	2.6	2.1	0.31	0.5
Ridge	4.7		0.19	

4.1.2 Crane Loading

$$\text{Moment @ B} = 1.5 * 225 = 337.5 \text{ kNm}$$

$$\text{Moment @ F} = 1.5 * 82 = 123 \text{ kNm}$$

$$\text{Horizontal load @ B \& @ F} = 1.5 * 13.9 = 20.8 \text{ kN}$$

Note: To find the total moment @ B and F we have to consider the moment due to the dead load from the weight of the rail and the gantry girder. Let us assume the weight of rail as 0.3 kN/m and weight of gantry girder as 2.0 kN/m

Dead load on the column = $\left(\frac{2+0.3}{2}\right) * 5 = 5.75 \text{ kN}$ acting at $e=0.6\text{m}$

Factored moment @ B & F = $1.5 * 5.75 * 0.6 = 5.2 \text{ kNm}$

Total moment @B = $337.5 + 5.2 = 342 \text{ kNm}$

@ F = $123 + 5.2 = 128 \text{ kNm}$

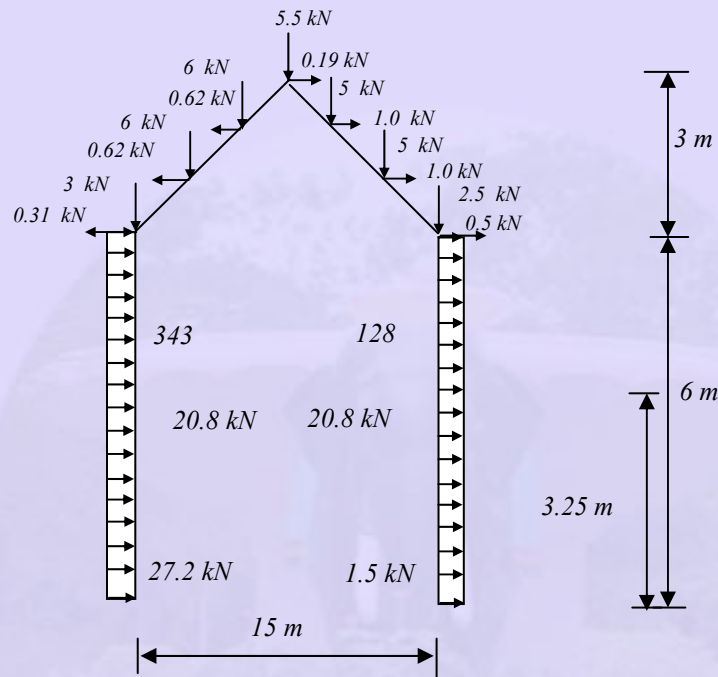

Factored Load (1.5D.L+1.5 C.L +1.05 W.L)

4.2 1.5 D.L + 1.5 C.L + 1.05 L.L

4.2.1 Dead Load and Live Load

@ intermediate points on windward side = $1.5 * 5.0 + 1.05 * 6.4$
= 14.2 kN

@ ridge = 14.2 kN

@ eaves = $14.2 / 2 \approx 7.1 \text{ kN}$.

4.2.2 Crane Load

Moment @ B = 342 kNm

Horizontal load @ B = 20.8 kN

Moment @ F = 128 kNm

Horizontal load @ F = 20.8 kN

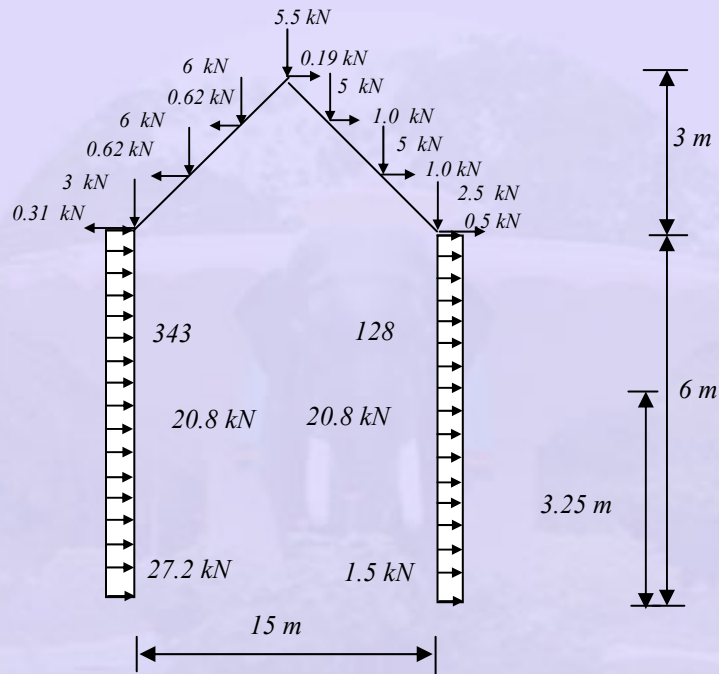

Factored Load (1.5D.L+1.5 C.L +1.05 W.L)

4.3 Mechanisms

We will consider the following mechanisms, namely

- (i) Beam mechanism
- (ii) Sway mechanism
- (iii) Gable mechanism and
- (iv) Combined mechanism
- (v) Beam Mechanism

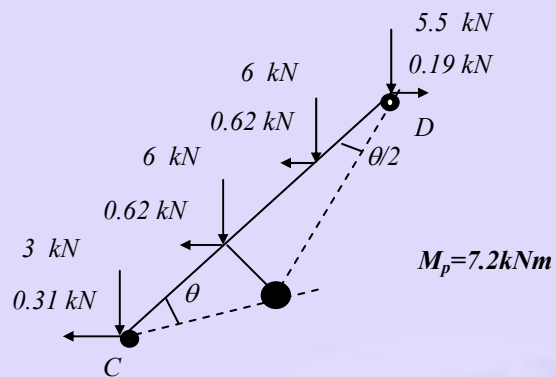
(1) Member CD**Case 1:** 1.5 D.L + 1.5 C.L + 1.05 W.L

$$\begin{aligned} \text{Internal Work done, } W_i &= M_p \theta + M_p (\theta/2) + M_p (\theta + \theta/2) \\ &= M_p (3\theta) \end{aligned}$$

$$\begin{aligned} \text{External Work done, } W_e &= 6 * 2.5\theta - 0.62 * 1 * \theta + 6 * 2.5 * \theta/2 - 0.62 * 1 * \theta/2 \\ &= 21.6\theta \end{aligned}$$

Equating internal work done to external work done

$$W_i = W_e$$

$$M_p (3\theta) = 21.6\theta$$

$$M_p = 7.2 \text{ kNm}$$

Case 2: 1.5 D.L + 1.5 C.L + 1.05 L.L

Internal Work done,

$$W_i = M_p 3\theta \quad (\text{as in case 1})$$

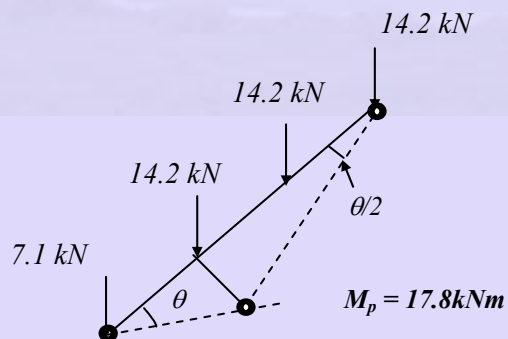

$$\begin{aligned} \text{External work done, } W_e &= 14.2 * 2.5\theta + 14.2 * 2.5\theta / 2 \\ &= 53.3\theta \end{aligned}$$

Equating $W_i = W_e$,

$$M_p (3\theta) = 53.3 \theta$$

$$M_p = 17.8 \text{ kNm}$$

Note: Member DE beam mechanism will not govern.

(2) Member AC

Internal Work done,

$$\begin{aligned} W_i &= M_p \theta + M_p \left(\theta + \frac{11}{13} \theta \right) + M_p \left(\frac{11}{13} \theta \right) \\ &= 3.69 M_p \theta \end{aligned}$$

$$M_p = 104.1 \text{ kNm}$$

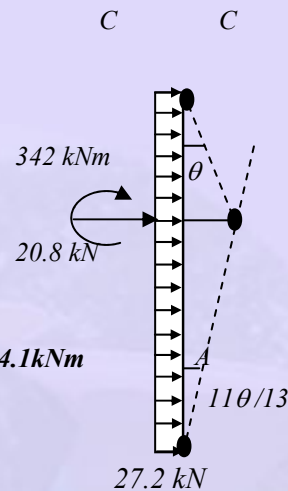

External Work done,

$$\begin{aligned} W_e &= 20.8 * 3.25 * \frac{11}{13} \theta + 342 * \frac{11}{13} \theta + \frac{1}{2} * 27.2 * 3.25 \left(\frac{11}{13} \theta \right) \\ &= 383.9 \theta \end{aligned}$$

Equating $W_i = W_e$, we get

$$3.69 M_p \theta = 383.9 \theta$$

$$M_p = 104.1 \text{ kNm.}$$

(3) Member EG

Internal Work done,

$$\begin{aligned} W_i &= M_p \theta + M_p \left(\theta + \frac{11}{13} \theta \right) + M_p \left(\frac{11}{13} \theta \right) \\ &= 3.69 M_p \theta \end{aligned}$$

$$M_p = 116.1 \text{ kNm}$$

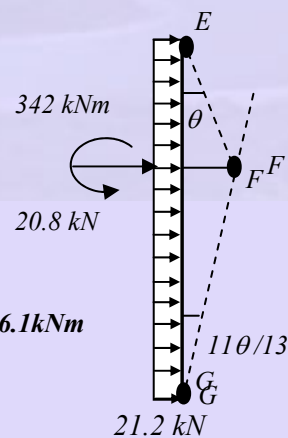

External Work done,

$$\begin{aligned} W_e &= 20.8 * 3.25 * \frac{11}{13} \theta + 342 * \theta + \frac{1}{2} (21.2) * 3.25 \left(\frac{11}{13} \theta \right) \\ &= 428.3 \theta \end{aligned}$$

Equating $W_i = W_e$, we get

$$3.69 M_p \theta = 428.30$$

$$M_p = 116.1 \text{ kNm}$$

For members AC & EG, the 1st load combination will govern the failure mechanism.

4.3.1 Panel Mechanism

Case 1: 1.5 D.L + 1.5 C.L + 1.05 W.L

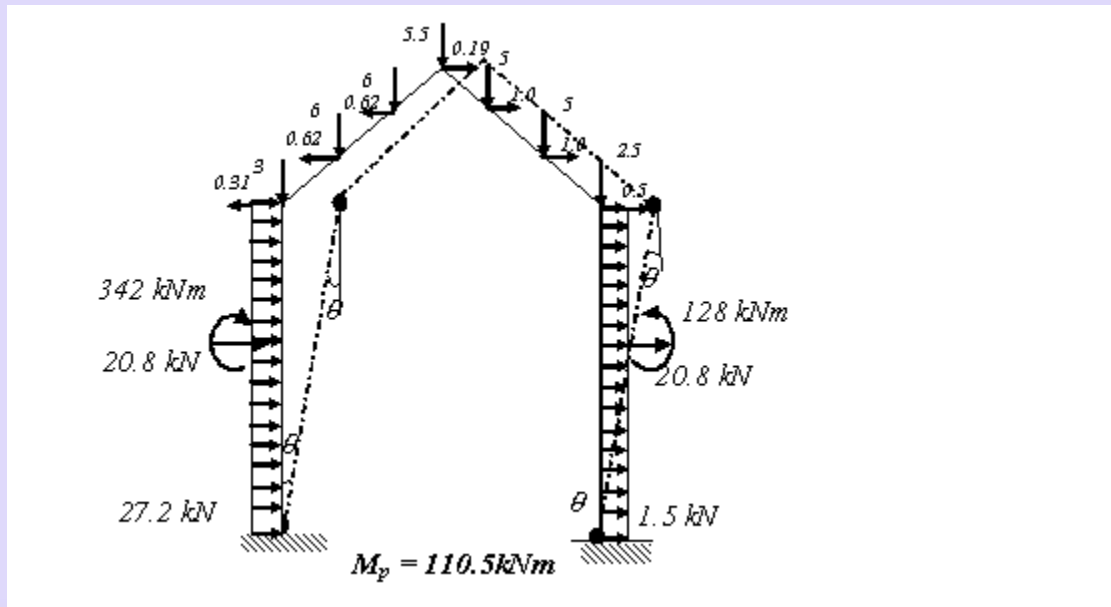

$$\text{Internal Work done, } W_i = M_p (\theta) + M_p (\theta) + M_p (\theta) + M_p (\theta)$$

$$= 4M_p \theta$$

$$\text{External Work done, } W_e$$

$$W_e = 1/2 (27.2) * 6\theta + 20.8 * 3.25\theta + 342\theta - 0.31 * 6\theta - 0.62 * 6\theta - 0.62$$

$$(6\theta) + 0.19 * 6\theta + 1.0 * 6\theta + 1.0 * 6\theta + 0.5 * 6\theta + 1/2 (1.5) * 6\theta +$$

$$20.8 * 3.25\theta - 128 * \theta$$

$$= 442.14\theta$$

Equating $W_i = W_e$, we get

$$4M_p \theta = 442.14\theta$$

$$M_p = 110.5 \text{ kNm}$$

The second load combination will not govern.

4.3.3 Gable Mechanism

Case 1: 1.5 D.L + 1.05 W.L + 1.5 C.L

Internal Work done = $M_p\theta + M_p2\theta + M_p(2\theta) + M_p\theta = 6M_p\theta$

External Work done, $W_e =$

$$-0.62 * 1 * \theta - 0.62 * 2 * \theta + 0.19 * 3 * \theta + 1.0 * 4 * \theta + 1.0 * 5 * \theta + 0.5 * 6 * \theta + 6 * 2.5 * \theta + 6 * 5 * \theta + 5.5 * 7.5 * \theta + 5 * 5 * \theta + 5 * 2.5 * \theta + \frac{1}{2} * 1.5 * 6\theta + 20.8 * 3.25 * \theta - 128 * \theta$$

$$W_e = 78.56\theta$$

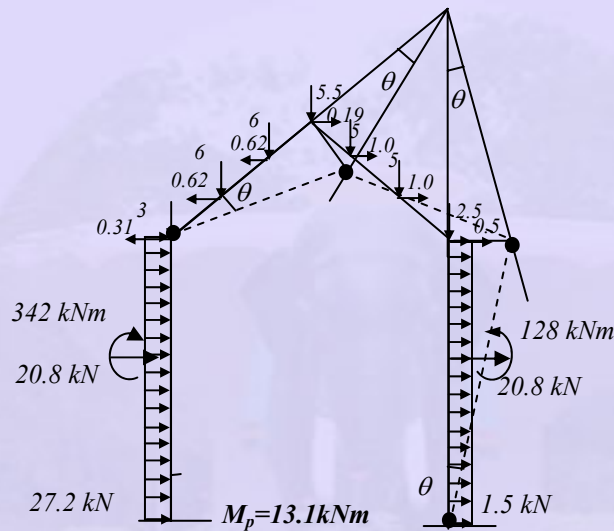

Equating $W_i = W_e$, we get

$$6M_p = 78.56\theta$$

$$M_p = 13.1 \text{ kNm.}$$

Case 2: 1.5 D.L + 1.05L.L + 1.5 C.L

$$M_p = 37.3 \text{ kNm}$$

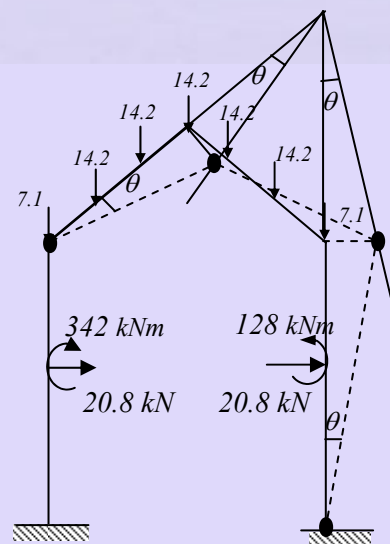

$$\text{Internal Work done, } W_i = M_p\theta + M_p(2\theta) + M_p(2\theta) + M_p\theta = 6M_p\theta$$

$$\text{External Work done, } W_e$$

$$= 14.2 * 2.5 * \theta + 14.2 * 5 * \theta + 14.2 * 7.5\theta + 14.2 * 5 * \theta + 14.2 * 2.5\theta - 128 * \theta + 20.8 * 3.25\theta$$

$$= 223.6\theta$$

$$\text{Equating } W_i = W_e, \text{ we get}$$

$$6M_p\theta = 223.6\theta$$

$$M_p = 37.3 \text{ kNm}$$

4.3.4 Combined Mechanism

$$\text{Case1: } 1.5 \text{ D.L} + 1.05 \text{ W.L} + 1.5 \text{ C.L}$$

(i)

$$\text{Internal Work done, } W_i = M_p(\theta) + M_p(\theta + \theta/2) + M_p(\theta/2 + \theta/2) + M_p(\theta/2)$$

$$= M_p(\theta + \theta + \theta/2 + \theta/2 + \theta/2 + \theta/2)$$

$$= 4 M_p\theta$$

$$M_p = 100.7$$

$$\text{External Work done, } W_e =$$

$$1/2 * 27.2 * 6\theta + 20.8 * 3.25 * \theta + 342\theta - 0.31 * 12 * \theta/2 - 0.62 * 11 * \theta/2$$

$$- 0.62 * 10 * \theta/2 + 0.19 * 9 * \theta/2 + 1.0 * 8 * \theta/2 + 1.0 * 7 * \theta/2 + 0.5 * 6 * \theta/2 + 1/2 (1.5) * 6\theta/2 + 20.8 * 3.25 * \theta/2 - 128 * \theta/2 - 6 * 2.5 * \theta/2 - 6 * 5.0 * \theta/2 - 5.5 * 7.5 * \theta/2 - 5 * 5 * \theta/2 - 5 * 2.5 * \theta/2$$

$$= 402.86\theta$$

$$\text{Equating } W_i = W_e$$

$$4M_p\theta = 402.86\theta$$

$$M_p = 100.7 \text{ kNm}$$

$$(ii) \text{ Internal work done, } W_i = M_p \theta / 2 + M_p (\theta / 2 + \theta / 2) + M_p (\theta / 2 + \theta) \\ + M_p \theta \\ W_i = 4M_p \theta$$

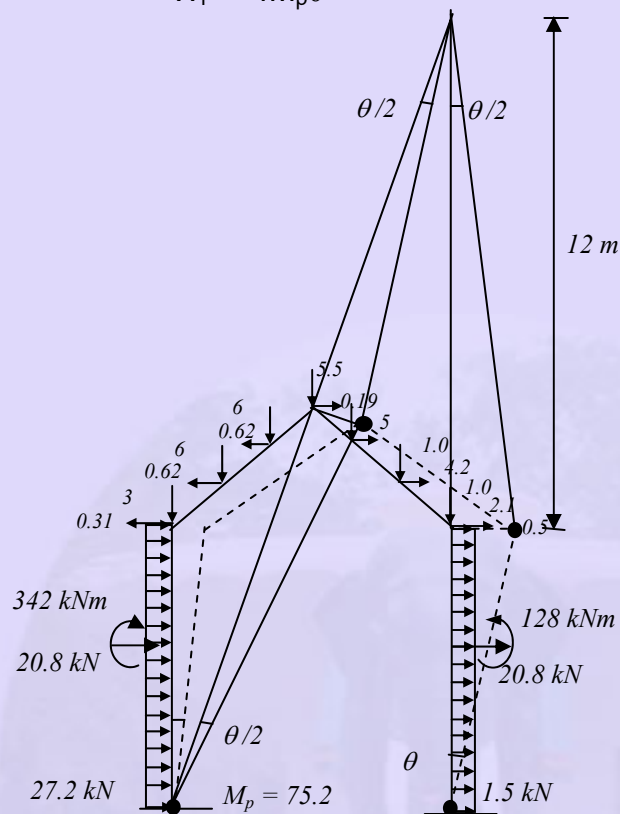

External Work done,

$$W_e = 20.8 * 3.25 * \frac{\theta}{2} + 342 * \frac{\theta}{2} + \frac{1}{2} * 27.2 * 6 \left(\frac{\theta}{2} \right) - 0.31 * 6 * \frac{\theta}{2} - 0.62 * 7 * \frac{\theta}{2} \\ - 0.62 * 8 * \frac{\theta}{2} + 0.19 * 9 * \frac{\theta}{2} + 6 * 2.5 * \frac{\theta}{2} + 6 * 5.0 * \frac{\theta}{2} + 5.5 * 7.5 * \frac{\theta}{2} + 1.0 * 10 * \frac{\theta}{2} \\ + 1.0 * 11 * \frac{\theta}{2} + 0.5 * 12 * \frac{\theta}{2} + 5 * 5.0 * \frac{\theta}{2} + 5 * 2.5 * \frac{\theta}{2} + 20.8 * 3.25 \theta - 128 * \theta \\ + \frac{1}{2} * 1.5 * 6 \theta \\ = 300.85 \theta$$

Equating $W_i = W_e$, we get

$$4M_p \theta = 300.85 \theta$$

$$M_p = 75.2 \text{ kNm}$$

Similarly analysis can be performed for hinges occurring at purlin locations also but they have been found to be not critical in this example case

From all the above analysis, the largest value of M_p required was for member EG under
 1.5 DL + 1.5 CL + 1.05 WL

Therefore the Design Plastic Moment = 116.1 kNm.

5.0 DESIGN

For the design it is assumed that the frame is adequately laterally braced so that it fails by forming mechanism. Both the column and rafter are analysed assuming equal plastic moment capacity. Other ratios may be adopted to arrive at an optimum design solution.

5.1 Selection of section

Plastic Moment capacity required = 116 kNm

$$\begin{aligned} \text{Required section modulus, } Z_p &= M_p / f_{yd} \\ &= \frac{(116 * 10^6)}{250 / 1.10} \\ &= 510.4 * 10^3 \text{ mm}^3 \end{aligned}$$

ISMB 300 @ 0.46 kN/ m provides

$$Z_p = 683 * 10^3 \text{ mm}^3$$

$$b = 140 \text{ mm}$$

$$T_i = 13.1 \text{ mm}$$

$$A = 5.87 * 10^3 \text{ mm}^2$$

$$t_w = 7.7 \text{ mm}$$

$$r_{xx} = 124 \text{ mm}$$

$$r_{yy} = 28.6 \text{ mm}$$

5.2 Secondary Design Considerations

5.2.1 Check for Local buckling of flanges and webs

Flanges

$$\frac{b_f}{T_1} = \frac{136}{\sqrt{f_y}}$$

$$b_f = 140/2 = 70 \text{ mm}$$

$$T_1 = 13.1 \text{ mm}$$

$$t = 7.7 \text{ mm}$$

$$\frac{b_f}{T_1} = \frac{70}{13.1} = 5.34 < 8.6$$

Web

$$\frac{d_l}{t} \leq \left[\frac{1120}{\sqrt{f_y}} - \frac{1600}{\sqrt{f_y}} \left(\frac{P}{P_y} \right) \right]$$

$$\frac{300}{7.7} \leq \left[\frac{1120}{\sqrt{250_y}} - \frac{1600}{\sqrt{250_y}} (0.27) \right]$$

$$38.9 \leq 68, \text{Hence O.K}$$

5.2.2 Effect of axial force

Maximum axial force in column, $P = 40.5 \text{ kN}$

Axial load causing yielding, $P_y = f_{yd} * A$

$$\begin{aligned} &= \frac{250}{1.10} \times 5.87 * 10^3 \\ &= 1334 \text{ kN} \end{aligned}$$

$$\frac{P}{P_y} = \frac{40.5}{1334} = 0.03 < 0.15$$

Therefore the effect of axial force can be neglected.

5.2.3 Check for the effect of shear force

$$\begin{aligned}\text{Shear force at the end of the girder} &= P - w/2 \\ &= 40.5 - 6.8 \text{ kN} \\ &= 33.7 \text{ kN}\end{aligned}$$

Maximum shear capacity V_{ym} , of a beam under shear and moment is given by

$$\begin{aligned}V_{ym} &= 0.55 A_w * f_{yd} / 1.10 \\ &= 0.55 * 300 * 7.7 * 250 / 1.10 \\ &= 289 \text{ kN} \gg 33.7 \text{ kN}\end{aligned}$$

Hence O.K.

