

1. Find out the major product & provide mechanism?

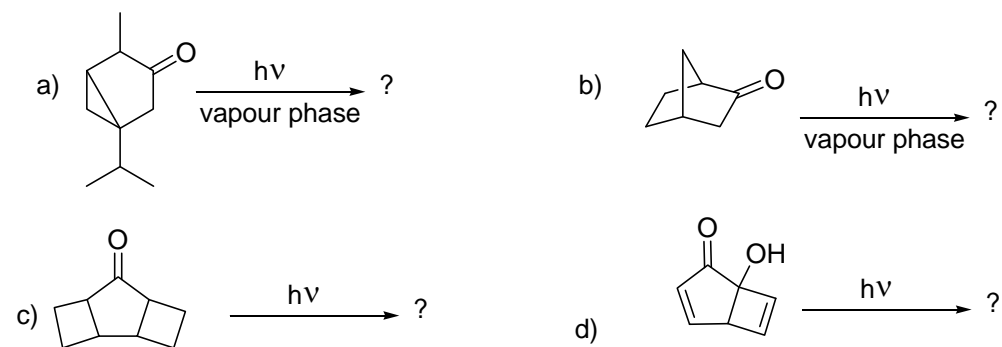

2. Give mechanism for the given transformation.

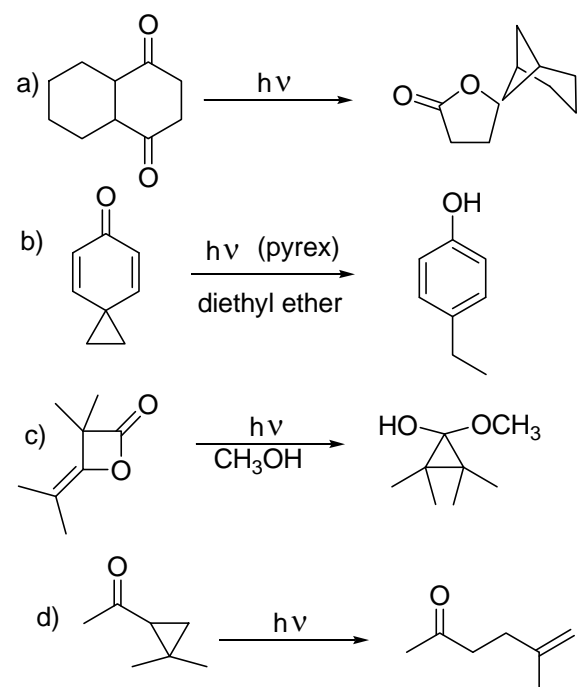

3. Complete the following reaction & give their mechanism?

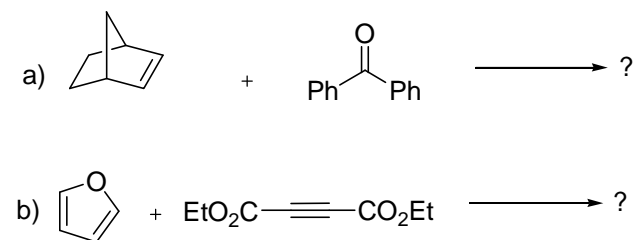



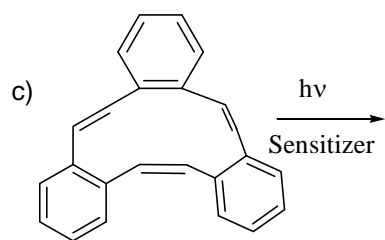

6. Write the major product & provide mechanism

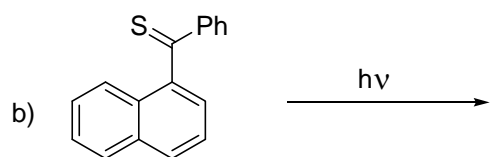
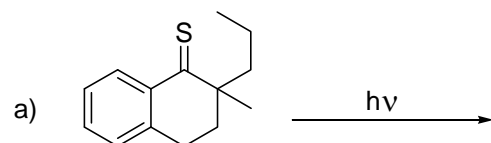

7. Find out the products in the following transformation.

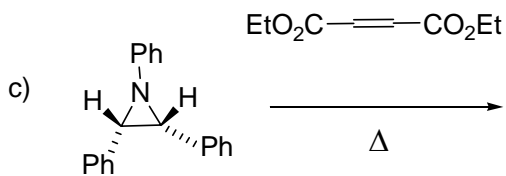
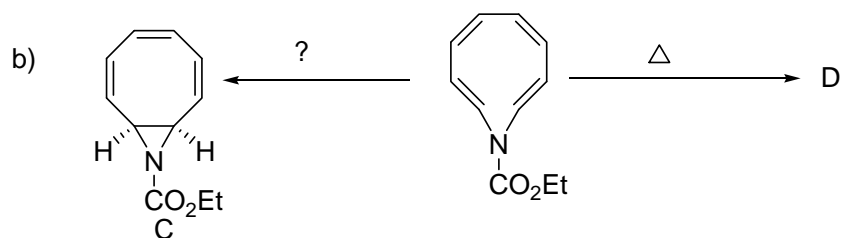
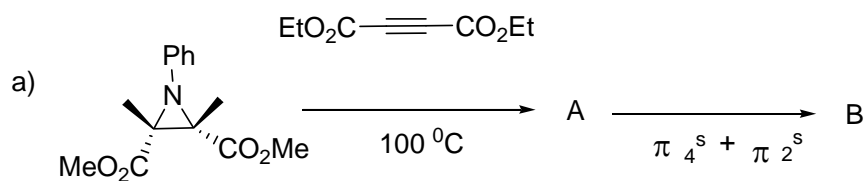

8) Suggest mechanism for the following transformation.

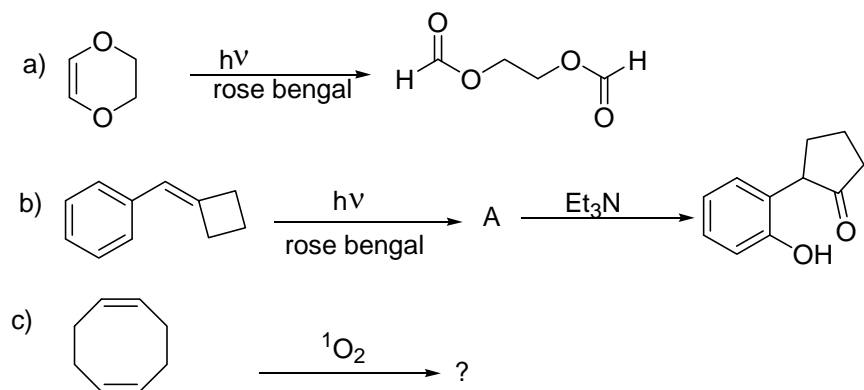

9. Predict the major product.

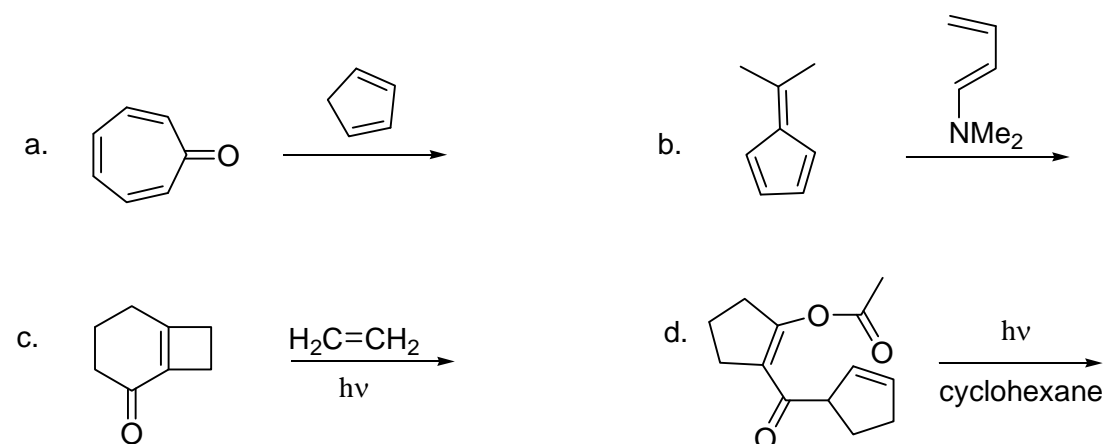

10. Complete the given reaction and give the mechanism.

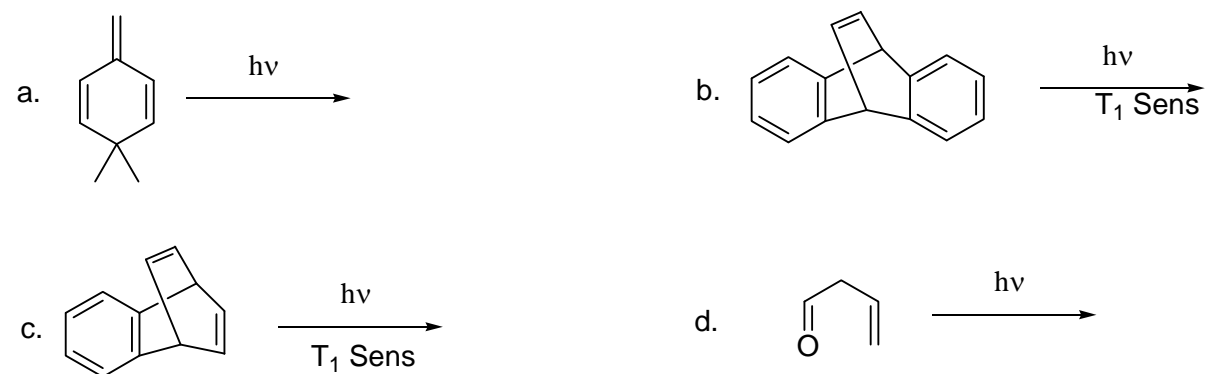

11. Write all the four products obtained in the given reaction

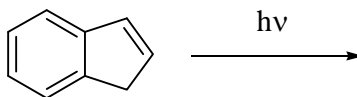

12. Find out the product A and B in the given transformation and explain the difference in the photoreaction



13. Find out the product missing in the given transformation

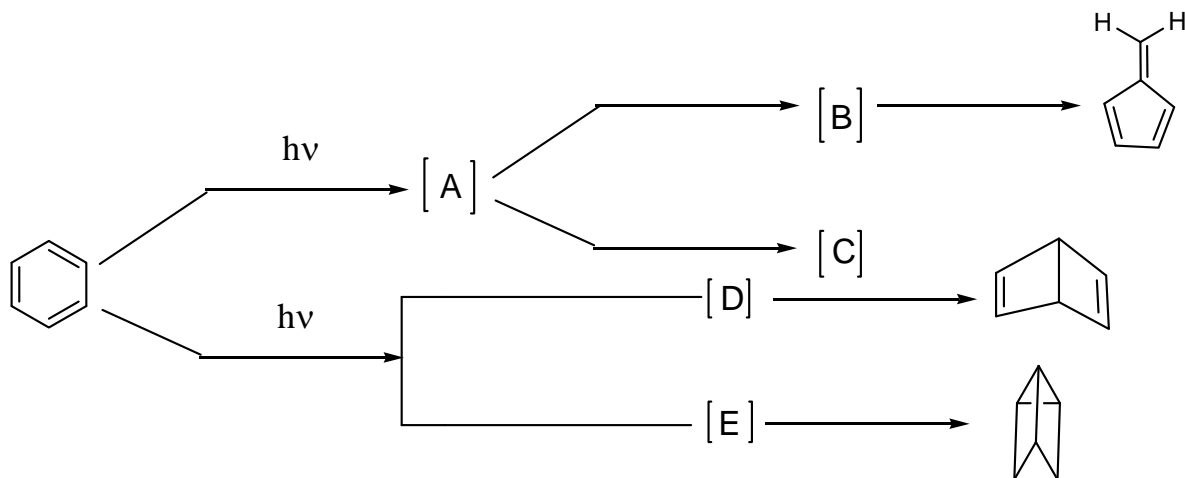

14. Predict the major product for the given transformation

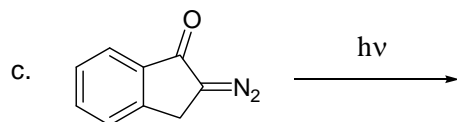
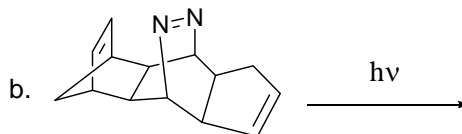
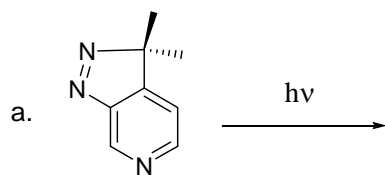

15. Predict the product of the following transformations

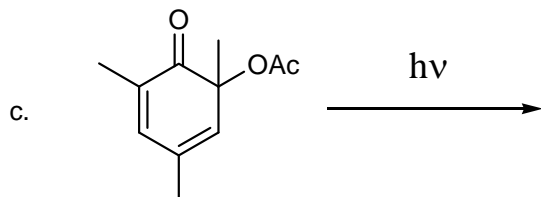
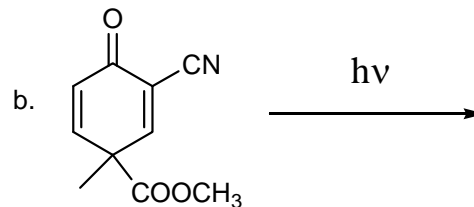
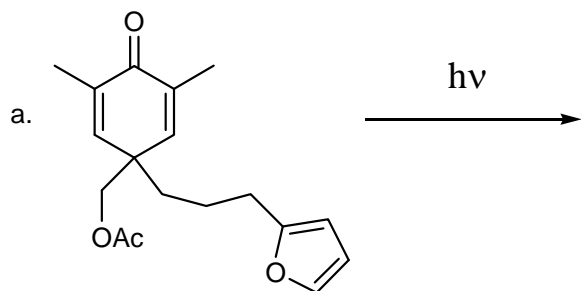

16. Find the intermediates formed during the following transformation

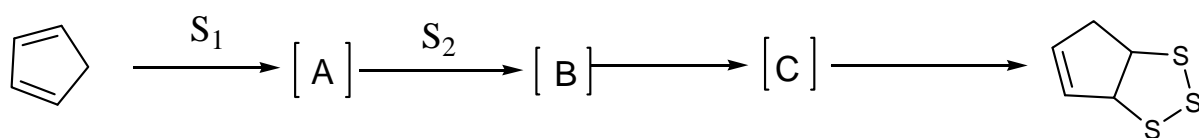

17. Predict the stereochemistry of the following pericyclic reaction

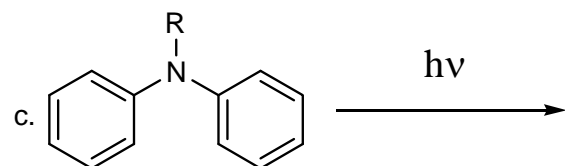
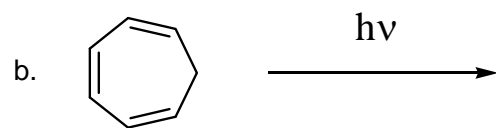
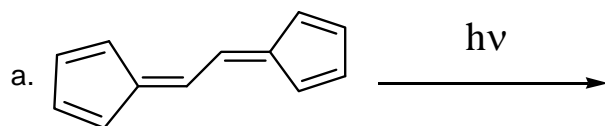

18. Predict the structure of 'A' and 'B' in the given transformation.

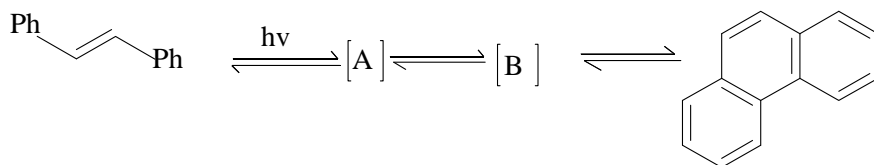

19. Predict the product

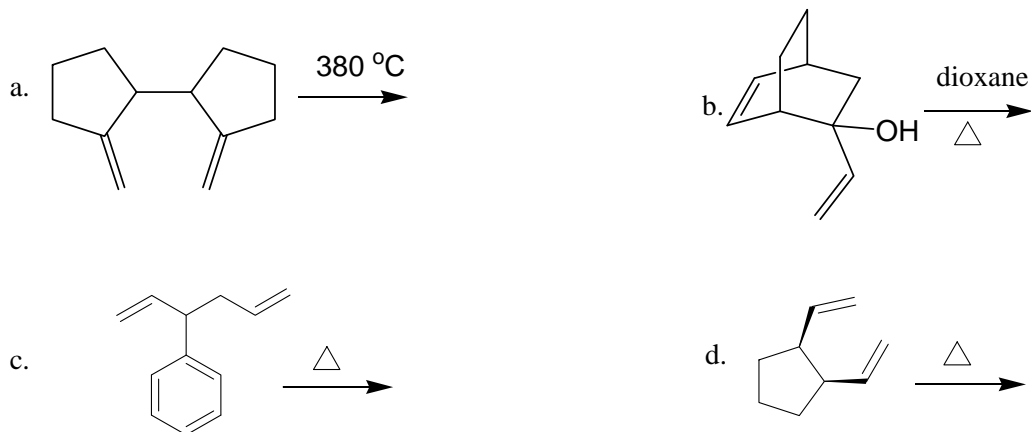

20. Predict the product.

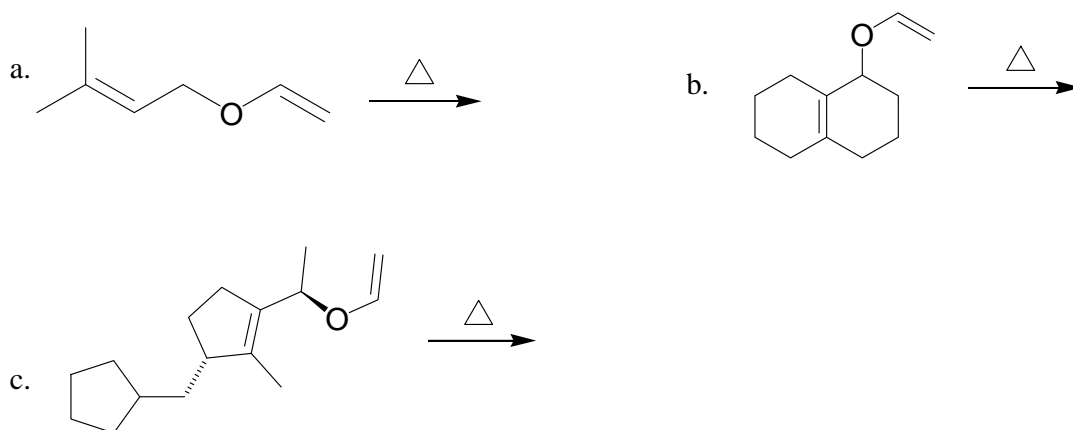

21. Write the product and give their mechanism.



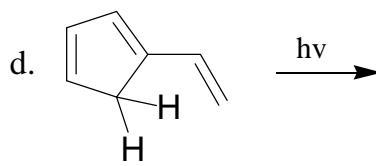
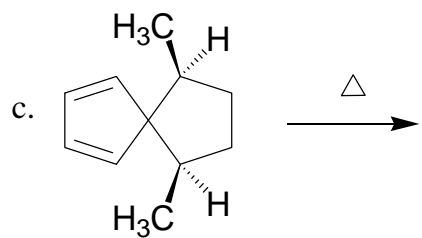

22. Write the major product

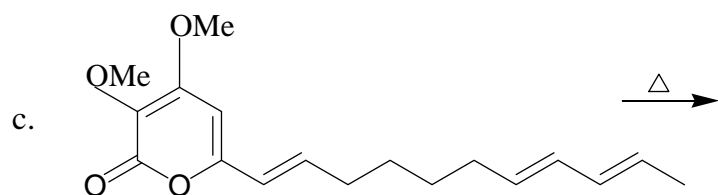
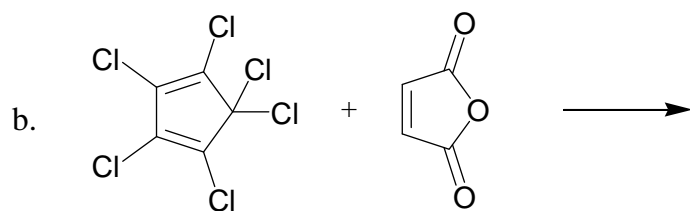
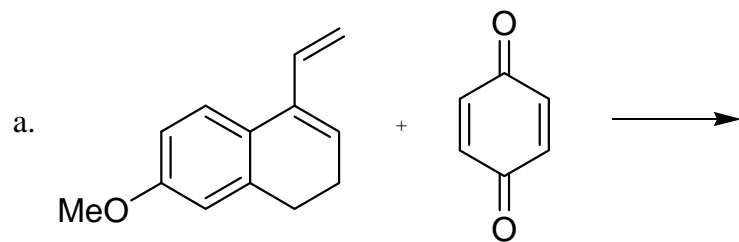

23. Find out the A and B in the following transformation.

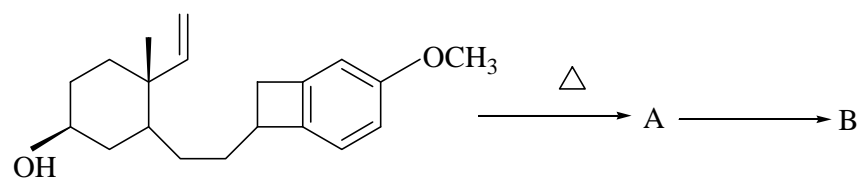

24. Find out A and B in the following transformation.



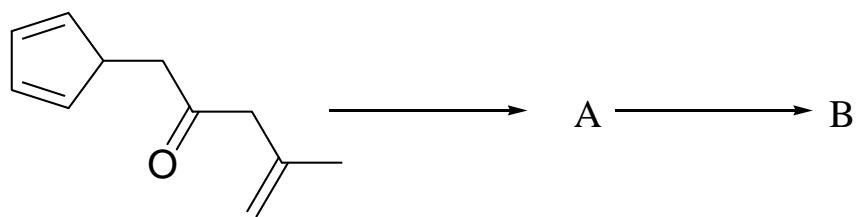

25. Find out the A and B in the following transformation.

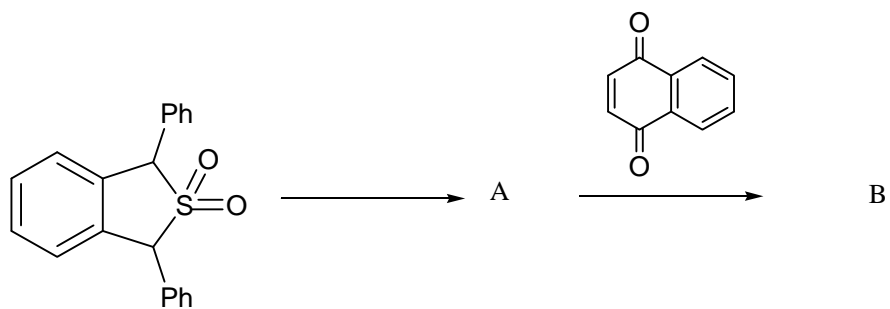

26. Find out the intermediates.

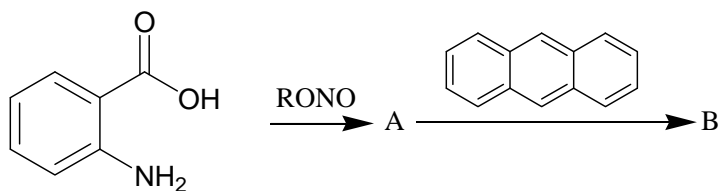

27. Find out the product.

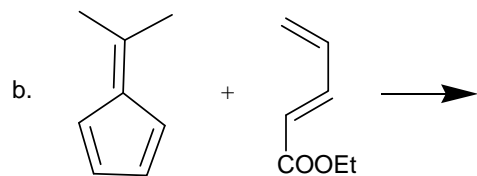
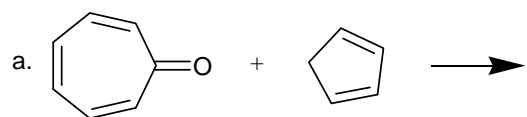

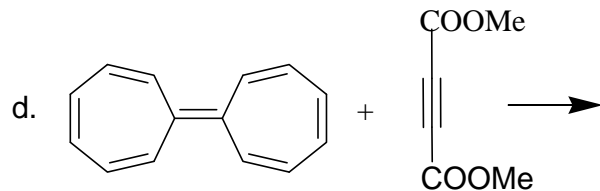
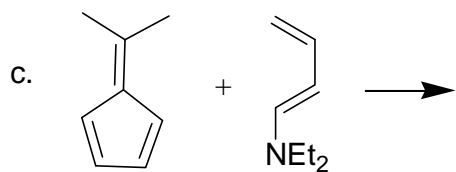

28. Find out the product.

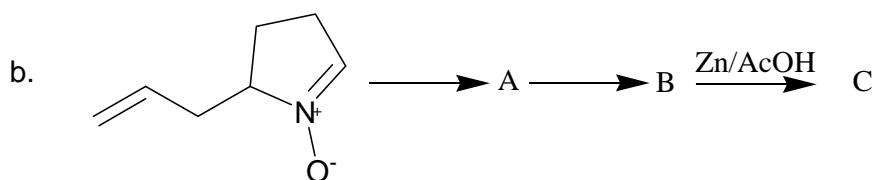
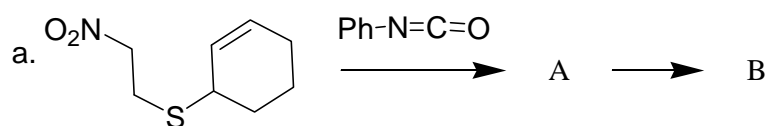

29. Predict the product.

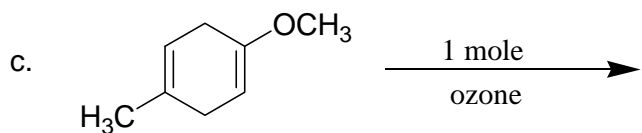
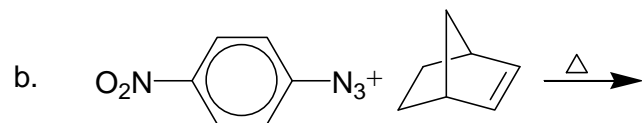
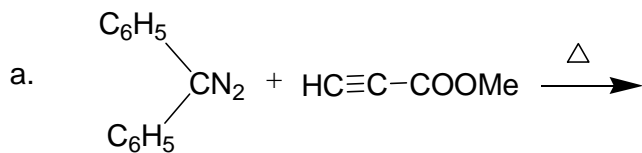

30. Predict the major photoproduct.

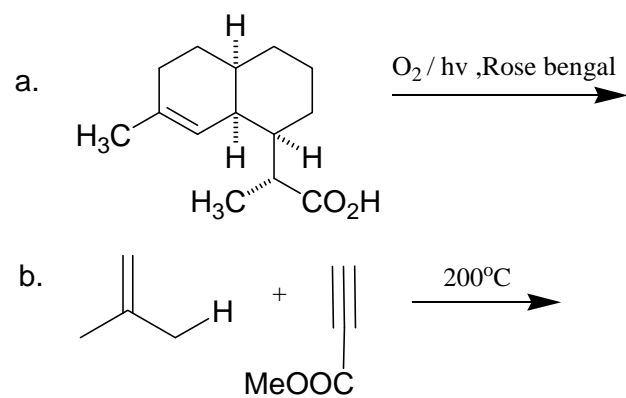

Problems were taken from

- (i) Modern Molecular Photochemistry: Nicholas J. Turro
- (ii) Organic photochemistry by Jan Kopecky
- (iii) Photochemistry and pericyclic reactions by jagdamba Singh and Jaya Singh